

Remarks on Lagrangian Intersections in Toric Manifolds

Miguel Abreu

(joint with **Leonardo Macarini** - UFRJ, **arXiv:1105.0640**)

Center for Mathematical Analysis, Geometry and Dynamical Systems
Instituto Superior Técnico, Lisbon, Portugal

2011

Introduction

- ▶ Lagrangian intersection questions play a fundamental role in symplectic topology.
- ▶ Two examples:
 - ▶ Arnold Conjectures.
 - ▶ Fukaya Category and Mirror Symmetry.
- ▶ Main tool: Floer (co)homology.
- ▶ Technical difficulties: cf. two-volume work of Fukaya-Oh-Ohta-Ono (FOOO), 2009 ~ 800 pages.

Introduction

- ▶ **Toric manifolds** provide examples that are both **interesting** and **tractable**.
- ▶ FOOO:
 - ▶ four preprints in arXiv since 2008 \sim 450 pages,
 - ▶ survey (2010) \sim 60 pages.
- ▶ Woodward (2010) \sim 70 pages.
- ▶ Simplest toric example: $(S^2, \sigma_{\text{area}})$ where the **equator** is a **non-displaceable** Lagrangian submanifold and **all other S^1 -orbits are displaceable**.

Toric Symplectic Manifolds

- ▶ A toric symplectic manifold is a connected symplectic $2n$ -manifold (M, ω) , equipped with an effective Hamiltonian action of the n -torus: $\mathbb{T}^n \hookrightarrow \text{Ham}(M^{2n}, \omega)$.
- ▶ The corresponding **moment map**, unique up to an additive constant, will be denoted by $\mu : M \rightarrow \mathbb{R}^n$.
- ▶ Atiyah-Guillemin-Sternberg'82: the image of the moment map is the convex polytope given by the convex hull of the images of the fixed points of the action. This will be called the **moment polytope** and denoted by $P := \mu(M) \subset \mathbb{R}^n$.
- ▶ Delzant'82: the moment polytope is a **complete invariant** of a compact toric symplectic manifold.

Moment Polytopes

The moment polytope $P \subset \mathbb{R}^n$ of a toric symplectic manifold (M^{2n}, ω) can be defined by

$$x \in P \Leftrightarrow \ell_i(x) := \langle x, \nu_i \rangle + a_i \geq 0, \quad i = 1, \dots, d,$$

where

- ▶ d is the number of facets of P ,
- ▶ each vector $\nu_i \in \mathbb{Z}^n$ is the primitive integral interior normal to the facet F_i of P ,
- ▶ the a_i 's are real numbers that determine $[\omega] \in H^2(M; \mathbb{R})$.

(M, ω) is **monotone**, i.e. $[\omega] = \lambda(2\pi c_1(\omega)) \in H^2(M; \mathbb{R})$ with $\lambda \in \mathbb{R}^+$, iff $P \subset \mathbb{R}^n$ can be defined as above with

$$a_1 = \dots = a_d = \lambda.$$

Such a P will be called a **monotone polytope** and note that, in this case, $0 \in P$.

Lagrangian Intersections in Toric Manifolds

- ▶ **Torus Fibers:** $x \in \check{P} := \text{interior}(P) \Rightarrow T_x := \mu^{-1}(x) \cong \mathbb{T}^n \equiv$ Lagrangian submanifold of (M, ω) . When P is monotone T_0 is called the **centered, special** or **monotone torus fiber**.
- ▶ **Real Part:** $\tau : M \rightarrow M$, $\tau^2 = \text{id}$, $\tau^*\omega = -\omega \Rightarrow R := M^\tau \equiv$ Lagrangian submanifold of (M, ω) .
- ▶ Explicit description in **action-angle coordinates:**

$\check{M} \equiv \mu^{-1}(\check{P}) \equiv \{\text{points of } M \text{ where } \mathbb{T}^n\text{-action is free}\}$

$\cong \check{P} \times \mathbb{T}^n = (x_1, \dots, x_n) \times (e^{i\theta_1}, \dots, e^{i\theta_n})$ such that

$\omega|_{\check{M}} = dx \wedge d\theta$, $\mu(x, e^{i\theta}) = x$ and $\tau(x, e^{i\theta}) = (x, e^{-i\theta})$

$\Rightarrow R \cap \check{M} = (x, \pm 1)$ and $\sharp(R \cap T_x) = 2^n$, $\forall x \in \check{P}$.

- ▶ Question: does there exist $\phi \in \text{Ham}(M, \omega)$ such that

$\phi(T_x) \cap T_x = \emptyset$ or $\phi(T_x) \cap R = \emptyset$ or $\phi(R) \cap R = \emptyset$?

Example

$(\mathbb{C}P^n, \omega_{FS})$ is a monotone toric symplectic manifold whose moment polytope $P \subset \mathbb{R}^n$ is the simplex given by

$$P = \{(x_1, \dots, x_n) : x_j + 1 \geq 0, j = 1, \dots, n; -\sum_{j=1}^n x_j + 1 \geq 0\}.$$

Moreover

$$R = \mathbb{R}P^n \quad \text{and} \quad T_0 = \text{Clifford torus}.$$

Biran-Entov-Polterovich and Cho, 2003:

$$\psi(T_0) \cap T_0 \neq \emptyset \quad \text{and} \quad \#(\psi(T_0) \pitchfork T_0) \geq 2^n, \quad \forall \psi \in \text{Ham}(\mathbb{C}P^n, \omega_{FS}).$$

Entov-Polterovich'07, Biran-Cornea'08 and Tamarkin'09:

$$\psi(T_0^n) \cap \mathbb{R}P^n \neq \emptyset, \quad \forall \psi \in \text{Ham}(\mathbb{C}P^n, \omega_{FS}).$$

Alston'09:

$$\#(\psi(T_0^{2n-1}) \pitchfork \mathbb{R}P^{2n-1}) \geq 2^n, \quad \forall \psi \in \text{Ham}(\mathbb{C}P^{2n-1}, \omega_{FS}).$$

Symplectic Reduction Remark

- ▶ $(\tilde{M}, \tilde{\omega})$: $\tilde{\mathbb{T}}$ -manifold of dimension $2N$, with moment map $\tilde{\mu} : \tilde{M} \rightarrow (\mathbb{R}^N)^*$.
- ▶ $K \subset \tilde{\mathbb{T}}$: subtorus of dimension $N-n$, determined by inclusion of Lie algebras $\iota : \mathbb{R}^{N-n} \rightarrow \mathbb{R}^N$.
- ▶ Induced action of K on \tilde{M} has moment map $\tilde{\mu}_K = \iota^* \circ \tilde{\mu} : \tilde{M} \rightarrow (\mathbb{R}^{N-n})^*$.
- ▶ $c \in \tilde{\mu}_K(\tilde{M}) \subset (\mathbb{R}^{N-n})^*$ regular value and consider level set $Z := \tilde{\mu}_K^{-1}(c) \subset \tilde{M}$.
- ▶ $(M := Z/K, \omega)$ is $\mathbb{T} := \tilde{\mathbb{T}}/K$ -manifold of dimension $2n$, with moment map $\mu : M \rightarrow P \subset (\mathbb{R}^n)^* \cong \ker(\iota^*)$ characterized by

$$\begin{array}{ccc} \tilde{M} \supset Z & \xrightarrow{\tilde{\mu}} & \tilde{P} \subset (\mathbb{R}^N)^* \\ \pi \downarrow & & \uparrow \\ M & \xrightarrow{\mu} & P \subset (\mathbb{R}^n)^* \end{array}$$

Symplectic Reduction Remark (cont.)

- ▶ $T_x := \mu^{-1}(x)$, $x \in \text{int}(P) \subset \text{int}(\tilde{P}) \Rightarrow \pi^{-1}(T_x) = \tilde{T}_x$.
- ▶ $\tilde{\tau}(Z) = Z$, $Z^{\tilde{\tau}} = Z \cap \tilde{R}$ and $\tilde{\tau}$ induces $\tau : M \rightarrow M$ via $\pi \circ \tilde{\tau} = \tau \circ \pi$.
- ▶ For $p \in R := M^\tau$ a simple counting argument shows that $\#(\pi^{-1}(p) \cap \tilde{R}) = 2^{N-n}$.

Lemma

Given $\psi \in \text{Ham}(M, \omega)$ there is $\tilde{\psi} \in \text{Ham}(\tilde{M}, \tilde{\omega})$ such that $\tilde{\psi}(Z) = Z$ and $\pi(\tilde{\psi}(\tilde{p})) = \psi(\pi(\tilde{p}))$, $\forall \tilde{p} \in Z$.

Symplectic Reduction Remark (cont.)

Proposition

$\psi, \tilde{\psi}$ as in Lemma and $x \in \text{int}(P) \subset \text{int}(\tilde{P})$. Then

$$(i) \#(\psi(T_x) \cap R) = r \Rightarrow \#(\tilde{\psi}(\tilde{T}_x) \cap \tilde{R}) = r2^{N-n}.$$

$$(ii) \psi(T_x) \cap T_x = \emptyset \Rightarrow \tilde{\psi}(\tilde{T}_x) \cap \tilde{T}_x = \emptyset.$$

Moreover

$$(iii) \#(\psi(T_x) \pitchfork T_x) = r \Rightarrow \exists \tilde{\varphi} \in \text{Ham}(\tilde{M}, \tilde{\omega}) : \\ \#(\tilde{\varphi}(\tilde{T}_x) \pitchfork \tilde{T}_x) = r2^{N-n}.$$

Remark

Dusa McDuff's *probes*, so far the only *displaceability tool* for torus fibers, can be thought of as a *particular case of (ii)*.

Symplectic Reduction Remark (cont.)

Corollary

(i) If $\#(\tilde{\psi}(\tilde{T}_x) \cap \tilde{R}) \geq m$ for any $\tilde{\psi} \in \text{Ham}(\tilde{M}, \tilde{\omega})$ then

$$\#(\psi(T_x) \cap R) \geq \frac{m}{2^{N-n}}, \quad \forall \psi \in \text{Ham}(M, \omega).$$

(ii) $\tilde{T}_x \subset (\tilde{M}, \tilde{\omega})$ *non-displ.* $\Rightarrow T_x \subset (M, \omega)$ *non-displ.*

(iii) If $\#(\tilde{\psi}(\tilde{T}_x) \pitchfork \tilde{T}_x) \geq m$ for any $\tilde{\psi} \in \text{Ham}(\tilde{M}, \tilde{\omega})$ then

$$\#(\psi(T_x) \pitchfork T_x) \geq \frac{m}{2^{N-n}}, \quad \forall \psi \in \text{Ham}(M, \omega).$$

Remark

Tamarkin uses similar idea in his work on microlocal analysis of sheaves and Lagrangian intersections. Also present in the work of *Borman* on reduction properties of quasi-morphisms and quasi-states.

Applications - 1

- ▶ Alston: $\#(\psi(T_0^{2n-1}) \pitchfork \mathbb{R}P^{2n-1}) \geq 2^n$, $\forall \psi \in \text{Ham}(\mathbb{C}P^{2n-1})$.
- ▶ $\mathbb{C}P^{2n}$ obtained as **centered** reduction of $\mathbb{C}P^{2n+1}$



Figure: $\mathbb{C}P^2$ as reduction of $\mathbb{C}P^3$.

$$\Rightarrow \#(\psi(T_0^{2n}) \pitchfork \mathbb{R}P^{2n}) \geq \frac{2^{n+1}}{2} = 2^n \quad \text{for any } \psi \in \text{Ham}(\mathbb{C}P^{2n}).$$

Applications - 2

Toric (M^{2n}, ω) , moment polytope $P \subset \mathbb{R}^n$, normals $\nu_1, \dots, \nu_d \in \mathbb{Z}^n$.

- ▶ $\sum \nu_i = 0 \Rightarrow M$ is symplectic reduction of $\mathbb{C}P^{d-1}$.
- ▶ (M^{2n}, ω) monotone \Rightarrow reduction is centered.

Proposition

Under these two conditions, T_0 and the pair (R, T_0) are *non-displaceable*. Moreover,

$$\#(\psi(T_0) \pitchfork T_0) \geq 2^n, \quad \forall \psi \in \text{Ham}(M, \omega).$$

Remark

Can *remove zero-sum* condition by using *weighted* projective spaces (with work of Woodward and Cho-Poddar), obtaining general result due to Entov-Polterovich, Cho and FOOO.

Cartesian Product Remarks

- ▶ $L_1, L_2 \subset (M, \omega)$ Lagrangian submanifolds.

Non-trivial intersection properties of the pair $(L_1 \times L_1, L_2 \times L_2)$ in $(M \times M, \omega \times \omega)$ give rise to non-trivial intersection properties of the pair (L_1, L_2) in (M, ω) .

The extension of Alston's result on $\mathbb{C}P^{2n-1}$ to $\mathbb{C}P^{2n}$ can also be proved using this simple observation (A.-Macarini).

- ▶ If T_i or the pair (T_i, R_i) have non-zero Floer homology or are non-displaceable in (M_i, ω_i) , $i = 1, 2$, then the same should be true for the corresponding $T_1 \times T_2$ and $(T_1 \times T_2, R_1 \times R_2)$ in $(M_1 \times M_2, \omega_1 \times \omega_2)$.

OK for Lagrangian torus fibers in toric symplectic manifolds (e.g. using Woodward's set-up).

Applications - 3

Proposition

(M^{2n}, ω) **monotone** toric manifold with **symmetric** polytope $P \subset \mathbb{R}^n$, i.e. if $\nu \in \mathbb{Z}^n$ normal to a facet of P then $-\nu$ is also the normal to a facet of P . Then $\#(\psi(T_0) \frown R) \geq 2^n$ for any $\psi \in \text{Ham}(M)$ and this bound is **optimal**.

Proof.

P symmetric implies that M can be obtained as **reduction of a product of d copies of $\mathbb{C}P^1$** , $2d =$ number of facets of P .
 M monotone implies that $\mathbb{C}P^1$'s have the same area and **reduction is centered**. Hence, we get from previous remarks

$$\#(\psi(T_0) \frown R) \geq \frac{2^d}{2^{d-n}} = 2^n, \forall \psi \in \text{Ham}(M, \omega).$$

Since $\#(T_0 \frown R) = 2^n$ the bound is indeed optimal. □

Applications - 3 (cont.)

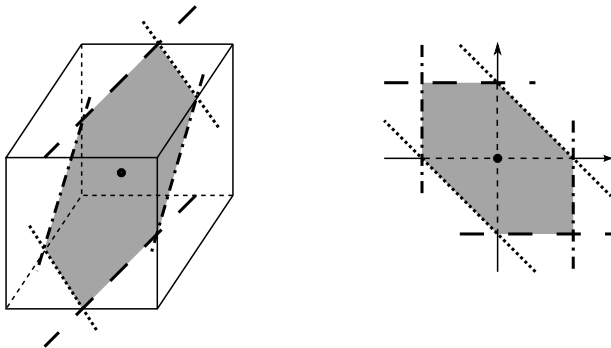
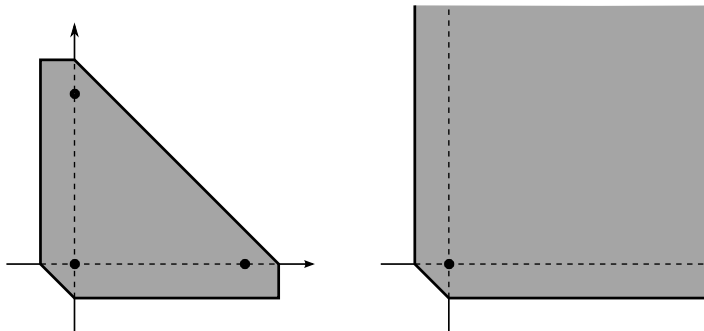

Figure: $\mathbb{C}P^2 \# 3\overline{\mathbb{C}P}^2$ as reduction of $\mathbb{C}P^1 \times \mathbb{C}P^1 \times \mathbb{C}P^1$.

One More Ingredient

In $\mathcal{O}(-1) \rightarrow \mathbb{C}P^1$, the special torus T_0 sitting over the origin in the polygon on the right side of the figure is **non-displaceable**. This follows from result of Cho (left side of figure) and was also directly proved by Woodward.



Application - 4: $M = \mathbb{C}P^2 \# \overline{\mathbb{C}P^2}$ (blow-up of $\mathbb{C}P^2$)

Two non-displaceable fibers when exceptional divisor is small.

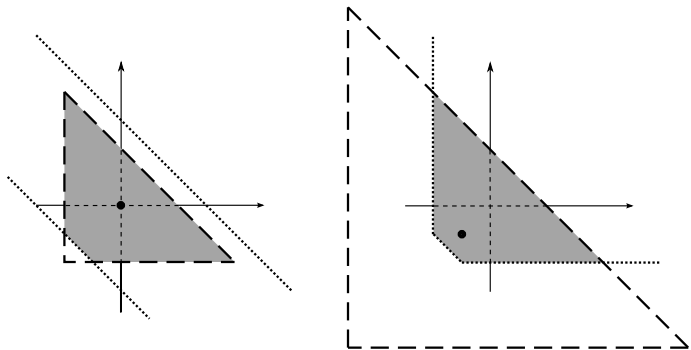

Figure: reduction of $\mathbb{C}P^2 \times \mathbb{C}P^1$ (left) and of $\mathcal{O}(-1) \times \mathbb{C}P^2$ (right).

Application - 4: $M = \mathbb{C}P^2 \# \overline{\mathbb{C}P^2}$ (blow-up of $\mathbb{C}P^2$)

One non-displaceable fiber when exceptional divisor is **big**.

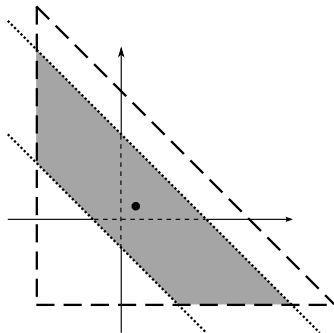

Figure: reduction of $\mathbb{C}P^2 \times \mathbb{C}P^1$, now with $\mathbb{C}P^2$ "bigger" than $\mathbb{C}P^1$.

Application - 5: $M = \mathbb{C}P^2 \# 2\overline{\mathbb{C}P^2}$

FOOO: with blow-ups of different sizes, one small and the other big, get closed **segment of non-displaceable fibers**.

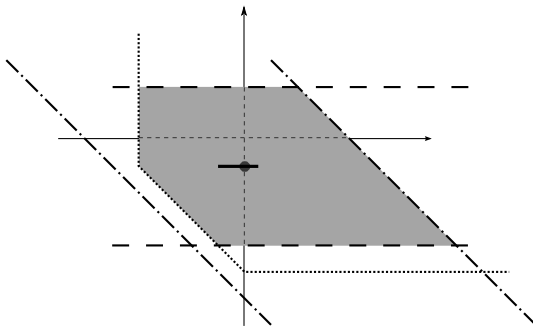

Figure: reduction of $\mathcal{O}(-1) \times \mathbb{C}P^1 \times \mathbb{C}P^1$.

One More Ingredient

Woodward and Cho-Poddar: the **special torus** fiber of a **weighted** projective space is **non-displaceable**.

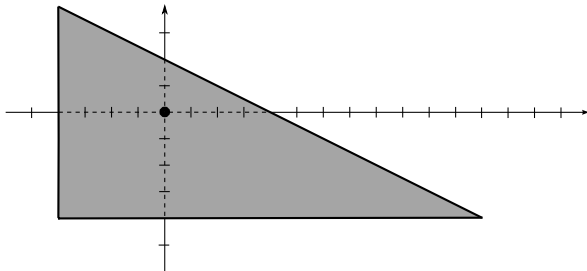

Figure: $\mathbb{C}P(1, 1, 2)$.

Application - 6: Hirzebruch surfaces

FOOO: any Hirzebruch surface has **at least one non-displaceable fiber**.

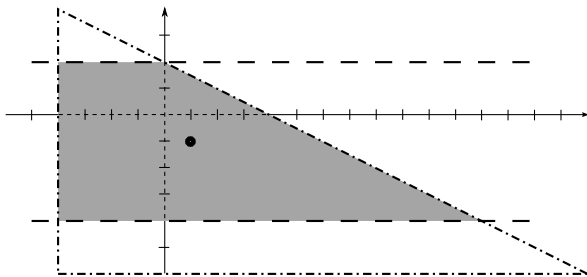

Figure: Hirzebruch surface H_2 as reduction of $\mathbb{C}P(1, 1, 2) \times \mathbb{C}P^1$.

Remark: Hirzebruch surfaces include **non-Fano** examples.

Application - 7: $M = H_2\#\overline{\mathbb{C}P}^2$ (non-Fano)

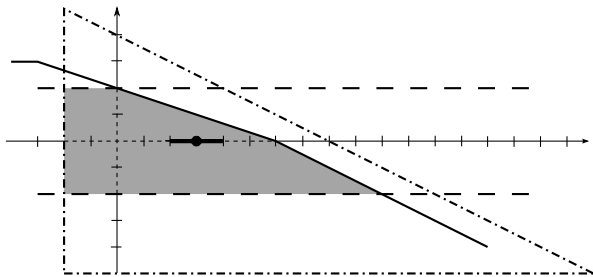

Figure: reduction of $\mathbb{C}P(1, 1, 2) \times \mathbb{C}P^1 \times \mathcal{O}(-1)$.

McDuff: this gives rise, under a repeated **wedge** construction, to a **monotone** toric 12-manifold with a **segment of fibers** that have **vanishing Floer homology** and **cannot be displaced by probes**. Still unknown if these are, in fact, (non-)displaceable.

Beyond Probes (A. – Borman – McDuff)

Observation 1: odd Hirzebruch surfaces have segment of fibers that cannot be displaced by probes.

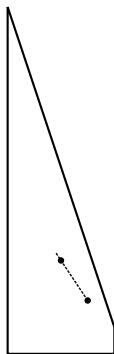

Figure: Hirzebruch surface H_3 .

Beyond Probes (A. – Borman – McDuff)

Observation 2: use Karshon's S^1 -equiv. symplectomorphisms $H_{\text{odd}} \rightarrow H_1 = \mathbb{C}P^2 \# \overline{\mathbb{C}P^2}$ to prove that fibers with $HF = 0$ are, in fact, **displaceable**.

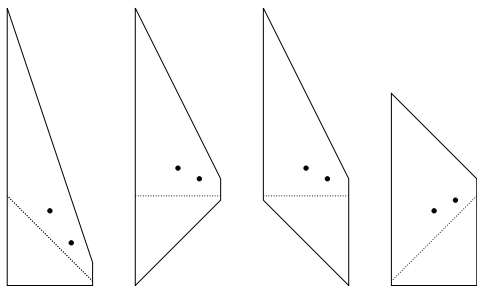

Figure: H_3 - left dot is **unique non-displaceable fiber**.

In progress: generalizations of this example to "probe" further the set of **displaceable fibers** on toric symplectic manifolds.