

# CODIMENSION ONE FOLIATIONS CALIBRATED BY NON-DEGENERATE CLOSED 2-FORMS

DAVID MARTÍNEZ TORRES

**ABSTRACT.** A class of codimension one foliations has been recently introduced by imposing a natural compatibility condition with a closed maximally non-degenerate 2-form. In this paper we study for such foliations the information captured by a Donaldson type submanifold. In particular we deduce that their leaf spaces are homeomorphic to leaf spaces of 3-dimensional taut foliations. We also introduce surgery constructions to show that this class of foliations is broad enough. Our techniques come mainly from symplectic geometry.

**AMS classification numbers:** 53C12, 57R30, 57R17, 53D12, 57R65, 53D17.

**Keywords:** Codimension one foliation; three dimensional taut foliation; leaf space; symplectic structure; Lagrangian sphere; generalized Dehn twist; Legendrian surgery; Lefschetz pencil.

## 1. INTRODUCTION AND STATEMENT OF MAIN RESULTS

Codimension one foliations are too large a class of structures to obtain strong structure theorems for them. According to a theorem of Thurston [38] a closed manifold admits a codimension one foliation if and only if its Euler characteristic vanishes. In order to draw significant results it is necessary to assume the existence of other structures compatible with the foliation.

From the point of view of symplectic geometry it is natural to consider the following class of codimension one foliations:

**Definition 1.** [21] *A codimension one foliation  $\mathcal{F}$  of  $M^{2n+1}$  is said to be 2-calibrated if there exists a closed 2-form  $\omega$  such that  $\omega_{\mathcal{F}^n}$  is no-where vanishing (we also say that  $\omega^n$  is no-where vanishing on  $\mathcal{F}$ ).*

*The 2-calibrated foliation is said to be integral if  $[\omega] \in H^2(M; \mathbb{Z})$ .*

The notation  $\omega_{\mathcal{F}^n}$  in definition 1 stands for the restriction of  $\omega^n$  to the leaves of  $\mathcal{F}$ . We will be using the subscript  $\mathcal{F}$  (respectively  $W$ , if  $W$  is a submanifold of  $M$ ) to denote the restriction of a form, connection, etc, to the leaves of  $\mathcal{F}$  (respectively to  $W$ ). In what follows the manifolds will always be closed and oriented, the codimension one foliations co-oriented and all the structures and maps smooth.

In the next paragraphs we are going to describe how the 2-calibrated condition appears naturally when looking at the problem of constructing submanifolds transverse to a codimension one foliation.

Recall that a codimension one foliation  $\mathcal{F}$  is said to be taut if every leaf meets a transverse 1-cycle. Tautness in codimension one can be characterized in several ways using forms, metrics and currents [37, 32, 18]. The characterization we are interested in, says that a rank  $p$  codimension one foliation  $\mathcal{F}$  is taut if and only if there exists a closed  $p$ -form  $\xi$  no-where vanishing on  $\mathcal{F}$  (and furthermore according to proposition 2.7 in [18], it is possible to construct a metric  $g$  so that  $\xi$  is a calibration for  $(M, \mathcal{F})$ ). Note in particular that a 2-calibrated foliation  $(M, \mathcal{F}, \omega)$  is always taut, since  $\xi := \omega^n$  is no-where vanishing on  $\mathcal{F}$ . In dimension three 2-calibrated foliations are the same as taut foliations.

Let us analyze one direction of the aforementioned characterization: the existence of a closed  $p$ -form whose restriction to each leaf is a volume form, is equivalent to a reduction of the structural pseudogroup of  $(M, \mathcal{F})$  to  $\text{Vol}(\mathbb{R}^p, \Xi_{\mathbb{R}^p}) \times \text{Diff}(\mathbb{R})$ , where

$$\Xi_{\mathbb{R}^p} := dx_1 \wedge \cdots \wedge dx_p,$$

$x_1, \dots, x_p$  are coordinates on  $\mathbb{R}^p$ , and  $\text{Vol}(\mathbb{R}^p, \Xi_{\mathbb{R}^p})$  (respectively  $\text{Diff}(\mathbb{R})$ ) is the pseudogroup of local diffeomorphisms of  $\mathbb{R}^p$  (respectively  $\mathbb{R}$ ) preserving the volume form  $\Xi_{\mathbb{R}^p}$ . Let  $U$  be any open subset of a leaf of  $\mathcal{F}$ . Poincaré recurrence theorem implies that the flow of any vector field spanning  $\ker \xi$  defines a first return map from  $U' \subset U$  to  $U'' \subset U$ . A straightforward consequence is that closed transverse 1-cycles through any given  $x \in M$  can be constructed by slightly deflecting integral curves of  $\ker \xi$ .

The first return map belongs to the pseudogroup  $\text{Vol}(\mathbb{R}^p, \Xi_{\mathbb{R}^p})$ . If  $p = 2$ , that is, if we have a taut foliation on a 3-manifold, then under certain circumstances we can deduce interesting geometric information about the existence of more closed orbits (Poincaré-Birkhoff theorem). If  $p > 2$  we have little geometric control on the return map because assuming for simplicity that  $U'$  and  $U''$  are diffeomorphic to a ball, the only invariant is the total volume ([16], theorem 1). Therefore problems such as the existence of transverse submanifolds of dimension bigger than one seem difficult to attack.

It has been known for some time that the right setting to obtain higher dimensional generalizations of Poincaré-Birkhoff theorem is not volume geometry but symplectic geometry ([19], chapter 6; [26], chapter IV). It can be checked (see section 2) that the existence of a closed 2-form  $\omega$  which makes the leaves of  $(M, \mathcal{F})$  symplectic manifolds, amounts to a reduction of the structural pseudogroup of  $(M, \mathcal{F})$  to  $\text{Symp}(\mathbb{R}^{2n}, \Omega_{\mathbb{R}^{2n}}) \times \text{Diff}(\mathbb{R})$ , where  $\text{Symp}(\mathbb{R}^{2n}, \Omega_{\mathbb{R}^{2n}})$  is the pseudogroup of local diffeomorphisms of  $\mathbb{R}^{2n}$  preserving the standard symplectic form

$$\Omega_{\mathbb{R}^{2n}} := \sum_{i=1}^n dx_i \wedge dy_i.$$

Thus, return maps associated to the flow of vector fields generating  $\ker \omega$  belong to  $\text{Symp}(\mathbb{R}^{2n}, \Omega_{\mathbb{R}^{2n}})$ . Symplectomorphisms are much more rigid than transformations preserving the volume form  $\Omega_{\mathbb{R}^{2n}}^n = n! \Xi_{\mathbb{R}^{2n}}$ . They preserve the symplectic invariants of subsets of  $\mathbb{R}^{2n}$ , so for example these cannot be squeezed along symplectic 2-planes ([19], chapters 2 and 3; [26], section 12). Naively, one might try to construct transverse 3-manifolds by choosing tiny 2-dimensional symplectic pieces  $\Sigma$  inside a leaf, whose image by the first return map is a small 2-dimensional symplectic manifold that can be isotoped to  $\Sigma$  through symplectic surfaces. The isotopy would be used to connect both symplectic surfaces in nearby leaves, and thus get a piece of transverse 3-dimensional taut foliation. Of course this idea seems difficult to be carried out because different pieces should be combined to construct a closed 3-manifold. However, it provides some insight on why 2-calibrated foliations are expected to have embedded 3-dimensional taut foliations.

In [21], corollary 1.2, it was proved that for any 2-calibrated foliation  $(M, \mathcal{F}, \omega)$  there exists an embedding of a 3-dimensional submanifold  $W^3 \hookrightarrow M$ , such that  $W^3$  is transverse to  $\mathcal{F}$  and  $\omega_W$  is no-where vanishing on  $\mathcal{F}_W$ ; the 3-dimensional submanifold  $W^3$ , which inherits a taut foliation, is a Donaldson type submanifold [7, 2]. Its existence is an elementary consequence of the extension to 2-calibrated foliations of the approximately holomorphic techniques for symplectic manifolds introduced by Donaldson [7].

**1.1. Statement of results.** Let  $(M, \mathcal{F}, \omega)$  be a 2-calibrated foliation and let  $W \hookrightarrow (M, \mathcal{F})$  be a 3-dimensional Donaldson type submanifold. In this paper we are mainly concerned with finding out which properties of  $(M, \mathcal{F})$  are captured by  $W$ .

If  $F$  is a compact leaf of  $(M, \mathcal{F}, \omega)$ , an appropriate version of the Lefschetz hyperplane theorem ([7], proposition 39) asserts that  $W \cap F$  is connected. A codimension one foliation  $(M, \mathcal{F})$  has non-compact leaves unless it is a fibration over the circle (a mapping torus). If  $F$  is a non-compact leaf then describing global properties of  $W \cap F$  seems very difficult. Our main result is a rather surprising and counterintuitive global property of such intersections for appropriate Donaldson type submanifolds.

**Theorem 1.** *Let  $(M, \mathcal{F}, \omega)$  be a 2-calibrated foliation. Then there exists Donaldson type submanifolds  $W^3 \hookrightarrow (M, \mathcal{F})$ , such that for every leaf  $F$  of  $\mathcal{F}$  the intersection  $W \cap F$  is connected.*

**Remark 1.** *Any integral 2-calibrated foliation  $(M, \mathcal{F}, \omega)$  admits embeddings in complex projective spaces  $\mathbb{C}\mathbb{P}^N$  of large dimension, with the property that the ambient Fubini-Study symplectic form restricts to a multiple of  $\omega$  ([21], corollary 1.3). The 3-dimensional transverse submanifolds in theorem 1 can be arranged to appear as intersections of  $M \subset \mathbb{C}\mathbb{P}^N$  with appropriate projective subspaces. Theorem 1 should be understood as a leafwise Lefschetz hyperplane type result for  $\pi_0$ .*

An important consequence of theorem 1 is the following result:

**Theorem 2.** *Let  $(M, \mathcal{F}, \omega)$  be a 2-calibrated foliation. Then there exists a 3-dimensional embedded taut foliation such that the inclusion  $(W^3, \mathcal{F}_W) \hookrightarrow (M, \mathcal{F})$  descends to a homeomorphism of leaf spaces  $W/\mathcal{F}_W \rightarrow M/\mathcal{F}$ .*

*Thus, leaf spaces of 2-calibrated foliations are no more complicated than those of 3-dimensional taut foliations.*

A second goal of this paper is showing that 2-calibrated foliations are a broad enough class of foliations. In this respect there are three basic families of 2-calibrated foliations: products, cosymplectic foliations and symplectic bundle foliations.

In a product we cross a 2-calibrated foliation -typically a 3-dimensional taut foliation- with a (non-trivial) symplectic manifold, and put the product foliation and the obvious closed 2-form.

A cosymplectic foliation is a triple  $(M, \alpha, \omega)$ , where  $\alpha$  is a no-where vanishing closed 1-form and  $(M, \ker \alpha, \omega)$  is a 2-calibrated foliation.

A bundle foliation with fiber  $S^1$  is by definition an  $S^1$ -fiber bundle  $\pi: M \rightarrow X$  endowed with a codimension one foliation  $\mathcal{F}$  transverse to the fibers. If the base space admits a symplectic form  $\sigma$ , then  $(M, \mathcal{F}, \pi^* \sigma)$  is a 2-calibrated foliation which we refer to as a symplectic bundle foliation.

The second topic of this paper concerns the introduction of two surgery constructions for 2-calibrated foliations: normal connected sum and generalized Dehn surgery or Lagrangian surgery. Using surgery we have obtained the following result:

**Proposition 1.** *There exist 2-calibrated foliations (of dimension bigger than three) which are neither products, nor cosymplectic foliations, nor symplectic bundle foliations.*

The paper is organized as follows. In section 2 we introduce definitions and basic facts on 2-calibrated foliations, and address their relation to regular Poisson structures.

Section 3 describes how to adapt the normal connected sum for symplectic and Poisson manifolds to integral 2-calibrated foliations; this is the surgery used to prove proposition 1.

In section 4 we present a surgery based on generalized Dehn twists. Generalized Dehn surgery is the natural extension to 2-calibrated foliations of positive Dehn surgery along a curve in a leaf of a 3-dimensional taut foliation  $(M^3, \mathcal{F})$ .

It is a classical result of Lickorish [25] that positive Dehn surgery along a curve  $\gamma$  has an alternative description:  $\gamma$  carries a canonical framing and therefore it determines an elementary cobordism from  $M^3$  to  $M'$ , which amounts to attaching a 2-handle to the trivial cobordism  $M \times [0, 1]$ . The “new” boundary component  $M'$  is endowed with a canonical foliation which coincides with positive Dehn surgery on  $(M, \mathcal{F})$  along  $\gamma$ .

If  $(M^{2n+1}, \mathcal{F}, \omega)$  is a 2-calibrated foliation, a parametrized Lagrangian  $n$ -sphere inside a leaf of  $\mathcal{F}$  canonically determines the attaching of a  $(n + 1)$ -handle. We show that the corresponding elementary  $(2n + 2)$ -dimensional cobordism admits a symplectic structure, which induces a 2-calibrated foliation on the new boundary component of the cobordism. We call this construction Lagrangian surgery. In theorem 4 we extend Lickorish’ result by proving that generalized Dehn surgery and Lagrangian surgery produce equivalent 2-calibrated foliations. The importance of this result stems from the fact that the aforementioned symplectic elementary cobordisms do appear in a natural way associated to Lefschetz pencil structures. As a byproduct we get an application to contact geometry that we have included in an appendix: it is a proof of a result announced by Giroux and Mohsen [11], relating generalized Dehn surgery along a parametrized Lagrangian sphere  $L$  in an open book decomposition compatible with a contact structure, and Legendrian surgery along  $L$ . Results in this section require a fine analysis of the symplectic monodromy about the singular fiber of the complex quadratic form.

In section 5 we prove theorems 1 and 2. The main tool are Lefschetz pencil structures for  $(M, \mathcal{F}, \omega)$ , which are appropriate analogs of leafwise complex Morse functions and whose existence is an application of approximately holomorphic geometry for 2-calibrated foliations. A regular fiber of a Lefschetz pencil structure is a Donaldson type submanifold. A Lefschetz pencil structure admits a leafwise symplectic connection. Its associated leafwise symplectic parallel transport is the key ingredient to prove our main theorem relating the leaf space of any regular fiber of the pencil to the leaf space of  $(M, \mathcal{F}, \omega)$ . Symplectic parallel transport also allows us to compare the 2-calibrated foliations induced on different regular fibers. Namely, in theorem 7 we show that any two regular fibers of a Lefschetz pencil structure for  $(M, \mathcal{F}, \omega)$  are related by a sequence of symplectic handle attachings along Lagrangian spheres. By the symplectic analog of Lickorish’s result proved in section 4, we conclude that any two regular fibers of a Lefschetz pencil structure are related by a sequence of generalized Dehn surgeries. We finish the section by discussing some open problems.

The author is very grateful to the referee for his/her corrections and numerous suggestions.

## 2. DEFINITIONS AND BASIC RESULTS

In this section we introduce some basic definitions, results and examples. We also address the relation of 2-calibrated foliations to Poisson structures.

**Definition 2.** *Let  $(M, \mathcal{F}, \omega)$  be a 2-calibrated foliation and let  $l: N \hookrightarrow M$  be a submanifold. We say that  $N$  is a 2-calibrated submanifold if  $(N, l^*\mathcal{F}, l^*\omega)$  is a 2-calibrated foliation.*

The definition of a 2-calibrated foliation can be given locally.

**Definition 3.** *A 2-calibration for  $(M, \mathcal{F})$  is a reduction of its structural pseudogroup to  $\text{Symp}(\mathbb{R}^{2n}, \Omega_{\mathbb{R}^{2n}}) \times \text{Diff}(\mathbb{R})$ .*

Definitions 1 and 3 are equivalent. A standard Darboux type result (see for example [26], chapter 3, for basic material on symplectic geometry) implies that about any point in  $M$  there exists a foliated chart with coordinates  $x_1, y_1, \dots, x_n, y_n, t$  (the image of  $\mathcal{F}$  in  $\mathbb{R}^{2n+1}$  is the foliation by affine hyperplanes with constant coordinate  $t$ ), such that  $\omega$  is the pullback of

$$\omega_{\mathbb{R}^{2n+1}} := \sum_{i=1}^n dx_i \wedge dy_i.$$

It is clear that on a given manifold 2-calibrated foliations are an open subset of the set of codimension one foliations in the  $C^0$ -topology. More precisely, in the product space of codimension one foliations and closed 2-forms, pairs corresponding to 2-calibrated foliations are an open set in the  $C^0$ -topology.

The first examples of 2-calibrated manifolds are 3-dimensional taut foliations. In this paper we are concerned with higher dimensional 2-calibrated foliations. An elementary family is obtained by applying the product construction to 3-dimensional taut foliations and non-trivial symplectic manifolds.

Another important family of 2-calibrated foliations are cosymplectic foliations. Recall that they are given by a triple  $(M^{2n+1}, \alpha, \omega)$ ,  $\alpha$  a closed 1-form and  $\omega$  a closed 2-form such that  $\alpha \wedge \omega^n$  is a volume form. An example of cosymplectic foliation is a 2-calibrated foliation whose leaves are the fibers of a fibration over the circle; the closed 1-form defining the foliation is the pullback of any volume form on the circle. Each fiber is a closed symplectic manifold and the first return map associated to the kernel of the calibrating 2-form is a symplectomorphism. We refer to such cosymplectic foliations as symplectic mapping tori. In fact, symplectic mapping tori are characterized as cosymplectic foliations whose defining 1-form has rank one period lattice. This characterization implies that symplectic mapping tori are  $C^0$ -dense in cosymplectic foliations. The reason is that the defining 1-form can be approximated by closed 1-forms with rational periods.

Cosymplectic foliations appear naturally in symplectic geometry as follows: recall that a vector field  $Y$  on a symplectic manifold  $(Z, \Omega)$  is called symplectic if  $L_Y \Omega = 0$ . If  $Y$  is a symplectic vector field transverse to  $\partial Z$ , then its symplectic annihilator

$$\text{Ann}(Y)^\Omega = \{v \in TZ \mid \Omega(Y, v) = 0\}$$

is an integrable codimension one distribution. Since it contains the vector field  $Y$ , it induces a codimension one foliation  $\mathcal{F}$  on  $\partial M$ . Let  $\alpha := i_Y \Omega$ . It can be checked that  $(\partial M, \alpha_{\partial M}, \Omega_{\partial M})$  is a cosymplectic foliation.

The previous construction leads to an analogy between cosymplectic foliations and contact structures. The reason is that on a symplectic manifold  $(Z, \Omega)$  endowed with a vector field  $Y$  transverse to the boundary and satisfying  $L_Y \Omega = \Omega$ , the restriction of  $i_Y \Omega$  to  $\partial M$  is a contact form. Following this analogy, we define the Reeb vector field  $R$  of a cosymplectic foliation  $(M, \alpha, \omega)$  to be the vector field characterized by the equations  $i_R \omega = 0$ ,  $i_R \alpha = 1$ . The foliation is invariant under the flow of the Reeb vector field. In fact, a cosymplectic foliation can be defined as a 2-calibrated foliation endowed with a vector field  $R$  spanning the kernel of  $\omega$  and whose flow preserves the foliation; we say that  $R$  is a Reeb vector field.

A third family of 2-calibrated foliations are symplectic bundle foliations<sup>1</sup>, which are defined as bundle foliations with fiber  $S^1$  over symplectic manifolds. There is a very rough way of associating symplectic bundle foliations to any bundle foliation  $\pi: M \rightarrow X$  with fiber  $S^1$ . The latter is characterized by a conjugacy class of representations of  $\pi_1(X, x)$  in  $\text{Diff}(S^1)$ . A result of Gompf ([14], theorem 0.1) asserts

<sup>1</sup>This family of 2-calibrated foliations was pointed out to the author by the referee.

that there exist closed symplectic manifolds (of dimension 4) whose fundamental group isomorphic to  $\pi_1(X, x)$ .

**Example 1.** Let  $x_1, y_1, x_2, y_2, t$  be coordinates on  $\mathbb{R}^5$  and consider the canonical 2-form  $\omega_{\mathbb{R}^5}$ . It descends to  $\mathbb{T}^5 = \mathbb{R}^5/\mathbb{Z}^5$  to a closed 2-form  $\omega_{\mathbb{T}^5}$ . Let  $\mathcal{F}$  be any of the foliations on  $\mathbb{T}^5$  induced by a constant 1-form  $\alpha$  on  $\mathbb{R}^5$  whose kernel is transverse to  $\frac{\partial}{\partial t}$ . Then  $(\mathbb{T}^5, \alpha, \omega_{\mathbb{T}^5})$  is a 2-calibrated foliation. Its leaves are all diffeomorphic to  $\mathbb{R}^i \times \mathbb{T}^{4-i}$ , where  $i \in \{0, \dots, 4\}$  depends on the slopes of the kernel of the 1-form.

By construction  $(\mathbb{T}^5, \alpha, \omega_{\mathbb{T}^5})$  is both a cosymplectic foliation and a symplectic bundle foliation. It is a product (respectively a mapping torus) if and only if the leaves are diffeomorphic to  $\mathbb{R}^i \times \mathbb{T}^{4-i}$ ,  $i \leq 2$  (respectively  $\mathbb{T}^4$ ).

Deciding which manifolds admit a 2-calibrated foliation can be divided in several subproblems which in general are very hard. A 2-calibrated foliation  $(M, \mathcal{F}, \omega)$  is the superposition of several compatible structures. Firstly the foliation. Secondly the 2-form restricts to a closed non-degenerate foliated 2-form  $\omega_{\mathcal{F}}$ . The pair  $(\mathcal{F}, \omega_{\mathcal{F}})$  defines a (regular) Poisson structure on  $M$  and as such it is also defined by an appropriate bivector field  $\Pi$ . And thirdly the foliated symplectic form  $\omega_{\mathcal{F}}$  admits a lift to a global closed 2-form  $\omega$ .

Determining which codimension one foliations are the symplectic foliations of a Poisson structure is very complicated; there exist partial results which use h-principles and only apply to open manifolds [4, 5, 9]. The existence of a closed lift of a foliated 2-form  $\omega_{\mathcal{F}}$  is controlled by three obstructions associated to the spectral sequence which relates basic cohomology, leafwise cohomology and the cohomology of the total space [8] (see [1] for a treatment in the setting of Poisson geometry); if the foliation is defined by a closed 1-form, then the obstruction to the existence of a closed lift admits a simpler description ([17], section 2.2).

We would like to regard a 2-calibrated foliation as a codimension one regular Poisson manifold with a lift of  $\omega_{\mathcal{F}}$  to a closed 2-form  $\omega$ . We are not fully interested in the 2-form  $\omega$ , as the following definition reflects.

**Definition 4.** Let  $(M_j, \mathcal{F}_j, \omega_j)$ ,  $j = 1, 2$ , be 2-calibrated foliations. They are said to be equivalent if there exists a diffeomorphism  $\phi: M_1 \rightarrow M_2$  such that

- $\phi$  is a Poisson morphism or equivalence (it preserves the foliations together with the leafwise 2-forms);
- $[\phi^*\omega_2] = [\omega_1] \in H^2(M_1; \mathbb{R})$  and  $\phi$  preserves the co-orientations.

For symplectic mapping tori an equivalence is just a Poisson diffeomorphism preserving co-orientations. Alternatively, equivalent symplectic mapping tori are those with the same symplectic leaf and isotopic first return maps (the isotopy through symplectomorphisms).

As we shall see in the following sections, the notion of equivalence is the right one to remove the dependence on choices in our surgeries.

### 3. NORMAL CONNECTED SUM

In the previous section we saw that deciding whether a manifold supports a 2-calibrated foliation is very complicated. It is thus natural to look for procedures to build new 2-calibrated foliations out of given ones. In this section we introduce the normal connected sum of integral 2-calibrated foliations, and we use it to give examples of 2-calibrated foliations which do not belong to either of the three elementary families, hence proving proposition 1.

Symplectic normal connected sum is a surgery construction in which two symplectic manifolds are glued along two copies of the same codimension two symplectic submanifold, which enters in the manifolds with opposite normal bundles ([14],

theorem 1.3). A parametric version of this surgery gives rise to an analogous construction for regular Poisson manifolds ([20], theorem 1). We propose the following extension to integral 2-calibrated foliations.

**Theorem 3.** *Let  $(M_j^{2n+1}, \mathcal{F}_j, \omega_j)$ ,  $j = 1, 2$ , be integral 2-calibrated foliations. Let  $(N^{2n-1}, \mathcal{F}_N, \omega_N)$  be a 2-calibrated foliation which is a symplectic mapping torus. Assume that we have maps  $l_j: N \hookrightarrow M_j$ ,  $j = 1, 2$ , embedding  $N$  as a 2-calibrated submanifold of  $M_j$  (definition 2), such that the following properties hold:*

- (1) *The 2-calibrated foliations induced by the embeddings are equivalent to the given one  $(N, \mathcal{F}_N, \omega_N)$  (definition 4).*
- (2) *The normal bundles of  $l_j(N) \subset M_j$ ,  $j = 1, 2$ , are trivial.*
- (3) *The fiber of  $N \rightarrow S^1$  is simply connected.*

*Then there exist gluing maps  $\psi$  such the Poisson structure  $\Pi$  on  $M_1 \#_\psi M_2$  characterized by matching on  $M_j \setminus l_j(N)$  the Poisson structures  $\Pi_j$  associated to  $(M_j, \mathcal{F}_j, \omega_j)$ ,  $j = 1, 2$ , admits a lift to a 2-calibrated structure.*

*Proof.* By assumptions 1 and 2 Poisson surgery produces a Poisson structure  $\Pi$  on  $M_1 \#_\psi M_2$  [20]. Very briefly, there is a gluing map  $\psi$  identifying  $A_1 \rightarrow A_2$  annular neighborhoods of  $l_1(N)$  and  $l_2(N)$  (by this we mean tubular neighborhoods from which we remove  $l_j(N)$ ,  $j = 1, 2$ ) defined as follows: by assumption 2 the normal bundles are trivial and by Darboux-Weinstein theorem with parameters the (smooth) leaf space of  $N$  ([26], chapter 3), there exist trivializations in which  $\Pi_j$ ,  $j = 1, 2$ , split. One factor is the leafwise symplectic form on  $l_j(N)$  and the other one is the standard symplectic form  $dx \wedge dy$  on the normal disk with coordinates  $x, y$ . On each normal disk  $\psi$  is the unique rotationally independent symplectomorphism of the punctured disk of radius  $\delta > 0$  which reverses the orientation of the radii.

Let  $(\mathcal{F}, \omega_{\mathcal{F}})$  denote the foliation and leafwise symplectic form associated to  $\Pi$ . If there is a lift of  $\omega_{\mathcal{F}}$  to an integral closed 2-form  $\omega$ , then there must be a Hermitian line bundle  $L$  and a compatible connection  $\nabla$  such that

$$-2\pi i \omega = F_{\nabla},$$

where  $F_{\nabla}$  is the curvature of the connection.

Because  $w_j$ ,  $j = 1, 2$ , represent integral cohomology classes there exist  $(L_j, \nabla_j) \rightarrow M_j$  Hermitian line bundles with compatible connections such that

$$-2\pi i \omega_j = F_{\nabla_j}. \quad (1)$$

We look for a lift of  $\psi$  to a bundle isomorphism

$$\Psi: L_1|_{A_1} \rightarrow L_2|_{A_2},$$

to define a (Hermitian) line bundle

$$L := L_1 \#_{\Psi} L_2 \rightarrow M_1 \#_{\psi} M_2.$$

Let  $c_j$ ,  $j = 1, 2$ , denote the Chern classes of  $L_j|_{A_j}$ , which are integral lifts of the restrictions of  $w_j$  to  $A_j$ . An isomorphism lifting  $\psi$  exists if and only if

$$\psi^* c_2 = c_1 \in H^2(A_1; \mathbb{Z}). \quad (2)$$

Because the fiber of  $N \rightarrow S^1$  is simply connected, the Wang sequence for the mapping torus  $A_1 \rightarrow S^1$  implies that  $H^2(A_1; \mathbb{Z})$  is torsion free. Therefore equation (2) is equivalent to

$$[\psi^* w_2|_{A_2}] = [w_1|_{A_1}] \in H^2(A_1; \mathbb{R}). \quad (3)$$

Because  $w_j$ ,  $j = 1, 2$ , extend to  $A_j \cup l_j$  and the cohomology of the tubular neighborhoods is concentrated in  $l_j(N)$ , equation (3) is equivalent to

$$[l_2^* w_2] = [l_1^* w_1] \in H^2(N; \mathbb{R}),$$

which holds true because by assumption 1 the 2-calibrations induced by  $l_1$  and  $l_2$  on  $N$  are equivalent.

Therefore we obtain  $L \rightarrow M_1 \#_{\psi} M_2$  a Hermitian line bundle with two not everywhere defined compatible connections  $\nabla_1, \nabla_2$ , overlapping on  $A_1 \subset M_1 \#_{\psi} M_2$ . Remark that by equation (1) the leafwise curvatures match on  $A_1$ . We are going to use the assumptions to modify  $\nabla_1$  and  $\nabla_2$  (the latter away from  $l_2(N)$ ), so that we obtain the leafwise equality of connections on  $A_1$ . Then a convex combination of both connections associated to a partition of the unity subordinated to  $M_j \setminus l_j(N)$ ,  $j = 1, 2$ , is a connection on  $M_1 \#_{\psi} M_2$  whose leafwise curvature is  $-2\pi i \omega_{\mathcal{F}}$ .

The difference

$$l_1^* \nabla_1 - l_2^* \nabla_2 \quad (4)$$

is a leafwise closed 1-form on  $N$  (recall that  $N$  is a mapping torus and therefore all leaves are compact). By assumption 3 it is leafwise exact and therefore we can modify say  $\nabla_2$ , by adding a smooth leafwise primitive function so the 1-form in equation (4) is leafwise vanishing.

Triviality of the normal bundles implies the existence of normal forms for the leafwise connections on tubular neighborhoods of  $l_j(N)$ ,  $j = 1, 2$ , which only depend on the restrictions of the leafwise connections to  $l_j(N)$ ; the normal forms amount to fixing a primitive 1-form for  $dx \wedge dy$ . The connections can be assumed to coincide with the normal forms. Finally the difference  $\nabla_1 - \psi^* \nabla_2$  is not still leafwise vanishing; on each normal annulus it is the differential of an (explicit) function, and what we do is modifying accordingly  $\nabla_2$  on  $M_2 \setminus l_2(N)$ .

As for dependence of the construction on choices, remark that the choice of isotopy classes of trivializations of the normal bundles (the framings), may affect the diffeomorphism class of  $M_1 \#_{\psi} M_2$ . For fixed isotopy classes of trivializations of the normal bundles, the underlying Poisson structure is unique up to Poisson diffeomorphism. The reason is that the leafwise symplectic form is unique up to isotopy supported near  $N$ . This follows from an elementary argument which is going to be used several times: because the leaves of  $N$  have no first cohomology group the local path of symplectomorphisms provided by Moser's argument is Hamiltonian ([26], chapter 3). The choice of primitive Hamiltonian function can be done coherently for all leaves of  $N$ . By extending the corresponding function to a global one supported near  $N$ , we construct a path of transformations connecting both Poisson structures. Also, if we fix a isotopy class of lifts  $\Psi$ , the 2-calibrated structure provided by the normal connected sum is unique up to equivalence. This is because the cohomology class of the calibrating 2-form is the image in real cohomology of the first Chern class of the bundle  $L$ , which is fixed by the choice of isotopy class of lifts.  $\square$

**Remark 2.** *The hypothesis needed to define normal connected sum of regular Poisson manifolds are much weaker than the requirements in theorem 3. In particular the normal bundles  $l_j(N)$ ,  $j = 1, 2$ , are not required to be trivial, just opposite. Triviality of the normal bundles is necessary if we want to produce an integral 2-calibrated foliation extending the given Poisson structures  $\Pi_j$  on  $M_j \setminus l_j(N)$ ,  $j = 1, 2$ . The reason is that already in the symplectic setting, having non-trivial normal bundle gives rise to choices in the construction which result into symplectic forms with different volume; this is a well known issue that appears when blowing up symplectic submanifolds ([26], chapter 7).*

*Perhaps the assumptions in theorem 3 can be weakened if we just require the existence of a 2-calibration on the normal connected sum.*

The normal connected sum can be applied to construct integral 2-calibrated foliations, that use as building blocks 2-calibrated foliations which are products



and symplectic mapping tori, but which are neither products, nor cosymplectic foliations nor symplectic bundle foliations.

*Proof of proposition 1.* Let  $(P^4, \Omega)$  be an integral symplectic 4-manifold which contains a symplectic sphere  $S^2$  with trivial normal bundle; let  $A \in \mathbb{Z}$  be the induced area form on the sphere. Let  $\varphi \in \text{Symp}(P, \Omega)$  such that  $\varphi|_{S^2} = \text{Id}$ ; for example  $\varphi$  can be the identity. We define  $(M_1, \mathcal{F}_1, \omega_1)$  to be the symplectic mapping torus associated to  $\varphi$ .

Let  $(M_2, \mathcal{F}_2, \omega_2)$  be the product 2-calibrated foliation with factors any taut foliation  $(Y^3, \mathcal{F}^3, \sigma)$  and the sphere  $(S^2, A)$ ; via a small perturbation and a rescaling of  $\sigma$ , we may take  $\omega_2$  to be integral. Let  $C$  be a fixed transverse cycle for  $(Y^3, \mathcal{F}^3, \sigma)$  and  $\theta: S^1 \rightarrow C$  any fixed positive parametrization with respect to the co-orientation.

Let  $N^3$  be the result of applying the mapping torus construction to  $\text{Id} \in \text{Symp}(S^2, A)$  ( $N \cong S^1 \times S^2$ ). Since  $\varphi|_{S^2} = \text{Id}$ , there is an obvious embedding  $l_1: N \hookrightarrow M_1$ . The embedding  $l_2$  is the product map  $\theta \times \text{Id}: N \hookrightarrow M_2$ .

By construction the embeddings fulfill the hypothesis of theorem 3, so we obtain a 2-calibrated foliation  $(M_1 \#_{\psi} M_2, \mathcal{F}, \omega)$ .

We impose the following additional constraints on the summands to make sure that  $(M_1 \#_{\psi} M_2, \mathcal{F}, \omega)$  does not belong to the three basic families:

- $(Y^3, \mathcal{F}^3)$  contains compact and non-compact leaves.
- There is a compact leaf  $\Sigma$  of  $(Y^3, \mathcal{F}^3)$  which intersects  $C$  in exactly one point, and  $(P^4, \Omega)$  is an odd Hirzebruch surface ([26], chapter 4).
- The genus of  $\Sigma$  is greater than one, and  $\pi_1(Y)$  is not isomorphic to  $\pi_1(S^1 \times \Sigma)$ .

Because  $l_2(N)$  intersects each leaf of  $(M_2, \mathcal{F}_2)$  in a unique connected component, there is a one to one correspondence between leaves of  $(Y^3, \mathcal{F}^3)$  and leaves of  $(M_1 \#_{\psi} M_2, \mathcal{F})$ . This correspondence sends a leaf  $F$  of  $(Y^3, \mathcal{F}^3)$  to the leaf which contains  $(F \times S^2) \setminus (l_2(N) \cap (F \times S^2))$ . Because the leaves of  $(M_2, \mathcal{F}_2)$  are compact, the correspondence sends compact leaves to compact leaves and non-compact leaves to non-compact leaves. Since  $(Y^3, \mathcal{F}^3)$  contains compact and non-compact leaves so does  $(M_1 \#_{\psi} M_2, \mathcal{F}, \omega)$ , and hence it has non-trivial holonomy. Consequently,  $(M_1 \#_{\psi} M_2, \mathcal{F}, \omega)$  cannot be a cosymplectic foliation.

Let  $\Sigma$  be a compact leaf of  $\mathcal{F}^3$  which intersects  $C$  in one point. The correspondence between leaves described in the previous paragraph sends  $\Sigma$  to a compact leaf  $F_{\Sigma}$ , which is the symplectic normal connected sum of the odd Hirzebruch surface and  $(\Sigma \times S^2, p_1^* \omega_{|\Sigma} + p_2^* A)$  along a symplectic sphere with trivial normal bundle. At the differentiable level  $F_{\Sigma}$  is the normal connected sum of the trivial  $S^2$ -fibration over  $\Sigma$  and the twisted  $S^2$ -fibration over  $S^2$ , and hence it is the twisted  $S^2$ -fibration over  $\Sigma$  (the fibers of our fibrations have a coherent orientation, since they are symplectic). If  $F_{\Sigma}$  is diffeomorphic to a product of surfaces then we can only have  $F_{\Sigma} \cong S^2 \times \Sigma$ ; otherwise we could not have isomorphic fundamental groups. But then  $F_{\Sigma}$  would admit two different  $S^2$ -fibration structures, and this is in contradiction with [28]. Therefore  $(M_1 \#_{\psi} M_2, \mathcal{F}, \omega)$  cannot be a product.

If the normal connected sum is a symplectic bundle foliation  $\pi: M_1 \#_{\psi} M_2 \rightarrow X$ , then  $F_{\Sigma}$  is a covering space of  $X$ . Because the fundamental group of  $F_{\Sigma}$  is the fundamental group of  $\Sigma$ , our assumption on the genus of  $\Sigma$  implies that the covering must be trivial. Therefore  $\pi$  sends  $F_{\Sigma}$  diffeomorphically onto  $X$ . This also implies that the principal  $S^1$ -bundle has a section, so  $M_1 \#_{\psi} M_2$  is the trivial bundle  $S^1 \times F_{\Sigma}$ . Hence  $\pi_1(M_1 \#_{\psi} M_2)$  is diffeomorphic to  $\pi_1(S^1 \times \Sigma)$ . But applying Seifert-Van Kampen theorem to the open subsets  $M_1 \setminus l_1(N)$ ,  $M_2 \setminus l_2(N)$  gives that  $\pi_1(M_1 \#_{\psi} M_2)$  is diffeomorphic to  $\pi_1(Y)$ , and this contradicts the assumption on  $\pi_1(Y)$ .

□

## 4. GENERALIZED DEHN SURGERY

In this section we introduce our second surgery, generalized Dehn surgery. We give a first definition which is the most natural one from the viewpoint of foliation theory. We present a second approach via handle attaching along Lagrangian spheres; this is a very natural definition having into account the description of Legendrian surgeries in contact geometry ([39], section Elementary Cobordisms). We prove the equivalence of both constructions in theorem 4.

Generalized Dehn surgery is done, unlike normal connected sum, along a submanifold inside one of the leaves. Let  $(M, \mathcal{F}, \omega)$  be a 2-calibrated foliation. We orient  $M$  so that a positive transverse vector followed by a positive basis of the leaf with respect to the volume form  $\omega_{\mathcal{F}}^n$ , gives a positive basis.

Let  $T := T^*S^n$  and  $d\alpha_{\text{can}}$  its canonical symplectic structure. Let

$$\tau: T \rightarrow T$$

be a generalized Dehn twist. Recall that these are certain compactly supported symplectomorphisms of  $(T, d\alpha_{\text{can}})$  which induce the antipodal map on the zero section. Let  $T(\lambda)$  be the subset of cotangent vectors of length  $\leq \lambda$  with respect to the round metric. Generalized Dehn twists can be chosen to be supported in the interior of  $T(\lambda)$  for any fixed  $\lambda$ , and any two with such property are isotopic in  $\text{Symp}^{\text{comp}}(T(\lambda), d\alpha_{\text{can}})$ , the group of compactly supported symplectomorphisms ([36], lemma 1.10 in section 1.2). They are symplectic generalizations of Dehn twists on  $T^*S^1$ .

A parametrized Lagrangian sphere  $L \subset (M, \mathcal{F}, \omega)$  is a submanifold of a leaf  $F_L$  such that  $\omega_L \equiv 0$ , together with a parametrization  $l: S^n \rightarrow L$ . By a theorem of Weinstein ([26], chapter 3) there exists  $U$  a compact neighborhood of  $L$  inside  $F_L$  and  $\lambda > 0$ , such that  $l^{-1}: L \rightarrow S^n$  extends to a symplectomorphism

$$\varphi: (U, \omega_{\mathcal{F}}) \rightarrow (T(\lambda), d\alpha_{\text{can}}).$$

Let us assume that if  $n = 1$  the loop  $L$  has trivial holonomy; if  $n > 1$  the absence of holonomy is a consequence of Reeb's theorem. In a neighborhood of  $L$  the foliation is a product. We let  $R$  be a local positive Reeb vector field and we let  $\Phi_t^R$  denote its time  $t$  flow, which by definition preserves  $\mathcal{F}$ . Let  $\epsilon > 0$  small enough so that

$$\begin{aligned} \Phi^R: [-\epsilon, \epsilon] \times U &\longrightarrow M \\ (t, x) &\longmapsto \Phi_t^R(x) \end{aligned}$$

is an embedding. We introduce the following notation:

$$\begin{aligned} U(\epsilon) &:= \Phi^R([-\epsilon, \epsilon] \times U), & U_t &:= \Phi_t^R(U), \\ U^+(\epsilon) &:= \Phi^R([0, \epsilon] \times U), & U^-(\epsilon) &:= \Phi^R([-\epsilon, 0] \times U). \end{aligned} \quad (5)$$

The result of cutting  $U(\epsilon)$  along  $U$  is the manifold  $U^-(\epsilon) \amalg U^+(\epsilon)$  whose boundary contains  $U^- = U \times \{0\} \subset U^-(\epsilon)$ ,  $U^+ = U \times \{0\} \subset U^+(\epsilon)$ .

**Definition 5.** *Let  $L \subset (M, \mathcal{F}, \omega)$  be a parametrized Lagrangian sphere. If  $n = 1$  assume that  $L$  is a loop with trivial holonomy. Generalized Dehn surgery along  $L$  is defined by cutting  $M$  along  $U$  as above and then gluing back via the composition*

$$\chi: (U^-, \omega_{\mathcal{F}}) \xrightarrow{\varphi} (T(\lambda), d\alpha_{\text{can}}) \xrightarrow{\tau} (T(\lambda), d\alpha_{\text{can}}) \xrightarrow{\varphi^{-1}} (U^+, \omega_{\mathcal{F}}), \quad (6)$$

where  $\tau$  is any choice of generalized Dehn twist supported in the interior of  $T(\lambda)$  and we use the canonical identifications of  $U^-, U^+$  with  $U$ .

We denote the resulting foliated manifold by  $(M^L, \mathcal{F}^L)$ .

**Proposition 2.** *The foliation  $(M^L, \mathcal{F}^L)$  admits calibrations  $\omega^L$ . If  $n > 1$  then*

- (1)  $(M^L, \mathcal{F}^L, \omega^L)$  is unique up to equivalence;
- (2)  $[\omega]$  is integral if and only if  $[\omega^L]$  is integral;
- (3)  $\pi_i(M^L) \cong \pi_i(M)$  and  $H_i(M^L; \mathbb{Z}) \cong H_i(M; \mathbb{Z})$ ,  $0 \leq i \leq n - 1$ .

*Proof.* We restrict our attention to  $U(\epsilon)$ . After cutting  $U(\epsilon)$  along  $U$  and gluing back using the identification  $\chi$  in equation (6), we obtain

$$U^L(\epsilon) := U^-(\epsilon) \#_{\chi} U^+(\epsilon) \subset M^L.$$

Since the flow of  $R$  preserves both  $\omega$  and the foliation, the restriction of  $\omega$  to  $U^-(\epsilon)$  and  $U^+(\epsilon)$  defines closed 2-forms  $\omega^-$  and  $\omega^+$  independent of the coordinate  $t$ . When we glue  $U^-$  to  $U^+$  using  $\chi$ , being this map a symplectomorphism the 2-forms  $\omega^-$  and  $\omega^+$  induce on  $U^L(\epsilon)$  a 2-form  $\omega_{\epsilon}^L$ . Then

$$\omega^L := \begin{cases} \omega & \text{in } M^L \setminus U^L(\epsilon), \\ \omega_{\epsilon}^L & \text{in } U^L(\epsilon) \end{cases}$$

is the desired closed 2-form.

The 2-calibrated structure we obtain is unique up to equivalence. Firstly different identifications  $\varphi: (U, \omega_{\mathcal{F}}) \rightarrow (T(\lambda), d\alpha_{\text{can}})$  are related by a global Poisson diffeomorphism. The reason is the same as in the proof of the uniqueness statement of theorem 3:  $S^n$ ,  $n > 1$ , is simply connected. Secondly generalized Dehn twists are symplectically isotopic by an isotopy supported in a neighborhood of the sphere. Thirdly changing the Reeb vector field amounts to a change of variable in the coordinate  $t$ , and this does not modify the construction.

The calibration is a real cohomology class determined by its values on closed 2-chains (which by a theorem of Thom are always homologous to embedded surfaces). If  $n > 1$  the 2-chains can be homotoped to avoid the neighborhood  $U(\epsilon)$  of the Lagrangian sphere  $L$ , where  $\omega^L$  coincides with  $\omega$ . Hence the integrality of the 2-calibrated foliation is unaffected by the surgery.

The same general position arguments imply that maps from CW complexes of dimension less or equal than  $n$  can be homotoped to miss  $U(\epsilon)$ . Therefore homology and homotopy groups up to dimension  $n - 1$  are unaffected by the surgery.  $\square$

**Remark 3.** *A “framed” Lagrangian  $n$ -sphere [35] is a parametrized  $n$ -sphere up to isotopy and the action of  $O(n + 1)$ . Generalized Dehn twists associated to two parametrizations defining the same “framed” Lagrangian  $n$ -sphere are isotopic, the isotopy by symplectomorphisms supported in a compact neighborhood of the Lagrangian sphere (remark 5.1 in [35] or paragraph after lemma 1.10 in [36]). Therefore generalized Dehn surgery is well defined for “framed” Lagrangian spheres.*

**Remark 4.** *The flow of the local Reeb vector field  $R$  can be used to displace the Lagrangian sphere  $L$  to a new Lagrangian sphere  $L'$  inside a nearby leaf. It follows that  $(M^L, \mathcal{F}^L, \omega^L)$  and  $(M^{L'}, \mathcal{F}^{L'}, \omega^{L'})$  are equivalent.*

*If we use instead of  $\tau$  its inverse, we get a 2-calibrated foliation  $(M^{L^-}, \mathcal{F}^{L^-}, \omega^{L^-})$  referred to as negative generalized Dehn surgery along  $L$ ; negative generalized Dehn surgery is generalized Dehn surgery for the opposite co-orientation.*

*Generalized Dehn surgery along  $L$  and negative generalized Dehn surgery along  $L$  are inverse of each other.*

**4.1. Lagrangian surgery.** Let  $L \subset (M, \mathcal{F}, \omega)$  be a parametrized Lagrangian sphere, and let  $\nu(L)$  and  $\nu_{\mathcal{F}}(L)$  denote respectively a tubular neighborhood of  $L$  and a tubular neighborhood of  $L$  inside the leaf containing  $L$ . The parametrized Lagrangian sphere  $L$  carries a canonical framing  $\mu_L$ : because  $L$  is Lagrangian

$\nu_{\mathcal{F}}(L) \cong T^*L$  and we deduce

$$\nu(L) \cong \nu_{\mathcal{F}}(L) \oplus \underline{\mathbb{R}} \cong T^*S^n \oplus \underline{\mathbb{R}} \cong \underline{\mathbb{R}}^{n+1}|_{S^n}, \quad (7)$$

where in the last isomorphism in (7) a positive no-where vanishing section of  $\underline{\mathbb{R}}|_{S^n}$  is sent to the outward normal unit vector field. Therefore  $L$  determines up to diffeomorphism an elementary cobordism  $Z$ , which amounts to attaching a  $(n+1)$ -handle to the parametrized sphere  $L$  with framing  $\mu_L$  ([15], chapter 4). The boundary of the cobordism is  $\partial Z = M \amalg M^{\mu_L}$ .

This subsection addresses the construction of a 2-calibrated foliation  $(M^{\mu_L}, \mathcal{F}^{\mu_L}, \omega^{\mu_L})$  which extends  $(M, \mathcal{F}, \omega)$  on the complement of a neighborhood of  $L$  (the complement understood as a subset of both  $M$  and  $M^{\mu_L}$ ). We do it by using the relation between symplectic manifolds and cosymplectic foliations presented in section 2: we have to endow the cobordism  $Z$  with a symplectic form  $\Omega$  -at least in a neighborhood of the  $(n+1)$ -handle- and a symplectic vector field  $Y$  transverse to the boundary. This produces automatically a cosymplectic foliation on  $\partial Z$ , and that is how we obtain  $(M^{\mu_L}, \mathcal{F}^{\mu_L}, \omega^{\mu_L})$ . Remark that our strategy is the same one used in contact geometry to show that surgeries along Legendrian spheres give rise to new contact manifolds ([39], paragraph 3 in page 242).

The elementary cobordism  $Z$  is the result of gluing a  $(n+1)$ -handle to the trivial cobordism  $P_1 := M \times [-\varepsilon, \varepsilon]$ . We have to define symplectic structures and symplectic vector fields transverse to the boundary on both the trivial cobordism and the  $(n+1)$ -handle, in a way that is compatible with the gluing.

We start with the trivial cobordism  $P_1$ : by the coisotropic embedding [12] there is a unique choice of symplectic structure on  $P_1$  which extends the given closed 2-form  $\omega$  on  $M \times \{0\}$ . We now give a specific normal form for it which is convenient for the purpose of describing a compatible gluing with the  $(n+1)$ -handle: let us denote  $H_1 := \nu(L)$ . Since the gluing between the trivial cobordism and the  $(n+1)$ -handle occurs near  $\nu(L)$ , we can assume without loss of generality that  $P_1 = H_1 \times [-\varepsilon, \varepsilon]$ . Let  $(\mathcal{F}_1, \omega_1)$  denote the restriction of  $(\mathcal{F}, \omega)$  to  $H_1$ . We select  $R_1$  a positive Reeb vector field on  $H_1$  with dual (closed) defining 1-form  $\alpha_1$  ( $i_{R_1}\alpha_1 = 1$ ,  $\ker\alpha_1 = \mathcal{F}_1$ ). We let  $v$  be the coordinate on the interval  $[-\varepsilon, \varepsilon]$ , and we extend  $\alpha_1$  and  $\omega_1$  to  $H_1 \times [-\varepsilon, \varepsilon]$  independently of  $v$ .

We define on  $P_1$

$$\Omega_1 := \omega_1 + d(v\alpha_1),$$

which is a symplectic form provided  $\varepsilon$  is small enough.

As symplectic vector field on  $(P_1, \Omega_1)$  we take  $Y_1 := \frac{\partial}{\partial v}$ , which is transverse to  $H \times \{-\varepsilon\}$  and  $H \times \{\varepsilon\}$ .

We let  $P_2$  denote the  $(n+1)$ -handle. Before defining the symplectic form  $\Omega_2$  and a symplectic vector field  $Y_2$  on  $(P_2, \Omega_2)$ , we address the problem of gluing symplectic cobordisms.

**Lemma 1** ([12], Extension theorem). *Let  $(P_j, \Omega_j)$ ,  $j = 1, 2$ , be symplectic manifolds,  $H_j \subset P_j$  hypersurfaces and  $Y_j$  symplectic vector fields transverse to them, so that we have product structures  $H_j \times [-\varepsilon, \varepsilon]$ . Define  $\omega_j = \Omega_j|_{H_j}$ ,  $\alpha_j = i_{Y_j}\Omega_j|_{H_j}$  and  $\mathcal{F}_j$  the foliation integrating  $\ker\alpha_j$ ,  $j = 1, 2$ . Suppose that  $\phi: H_1 \rightarrow H_2$  is a diffeomorphism such that  $\phi^*\omega_2 = \omega_1$  and  $\phi^*\alpha_2 = \alpha_1$  (and therefore  $\phi^*\mathcal{F}_2 = \mathcal{F}_1$ ). Then*

$$\phi \times Id: (H_1 \times [-\varepsilon, \varepsilon], \Omega_1) \rightarrow (H_2 \times [-\varepsilon, \varepsilon], \Omega_2)$$

*is a symplectomorphism (obviously compatible with the symplectic vector fields).*

Lemma 1 is the analog of proposition 4.2 in [39].

In our specific situation of gluing near Lagrangian spheres, the amount of information needed to describe  $\phi$  as in lemma 1 is much smaller.

**Corollary 1.** *Let  $(P_j, \Omega_j, H_j, Y_j)$ ,  $j = 1, 2$ , be as in lemma 1 and assume further that  $L_j \subset H_j$  are Lagrangian spheres and  $P_j$  small tubular neighborhoods of  $L_j$ .*

*Let  $\theta: L_1 \rightarrow L_2$  be a diffeomorphism. Then  $\theta$  extends to an isomorphism of tuples*

$$(P_1, \Omega_1, H_1, Y_1) \rightarrow (P_2, \Omega_2, H_2, Y_2).$$

*Proof.* The symplectic vector fields give rise by contraction to closed 1-forms defining the foliations, and therefore to Reeb vector fields. We extend  $\theta$  to a symplectomorphism of neighborhoods of the spheres inside their leaves, and we further extend it to  $\phi: (H_1, \alpha_1, \omega_1) \rightarrow (H_2, \alpha_2, \omega_2)$  by declaring it to be equivariant with respect to the Reeb flows. By construction  $\phi$  is in the hypothesis of lemma 1.

Notice that the only choice is the identification of the symplectic neighborhoods of  $L_j$ ,  $j = 1, 2$ , inside their respective leaves.  $\square$

4.1.1. *The choice of symplectic form and symplectic vector field on the  $(n + 1)$ -handle.* Let  $W$  be a neighborhood of  $0 \in \mathbb{C}^{n+1}$ . This neighborhood will contain our  $(n + 1)$ -handle  $P_2$ .

Let us consider the complex Morse function

$$\begin{aligned} h: \mathbb{C}^{n+1} &\longrightarrow \mathbb{C} \\ (z_1, \dots, z_{n+1}) &\longmapsto z_1^2 + \dots + z_{n+1}^2. \end{aligned}$$

We take  $\Omega_2 \in \Omega^2(W)$  to be any symplectic form of type  $(1, 1)$  at the origin with respect to the standard complex structure of  $\mathbb{C}^{n+1}$ , and  $Y_2$  to be the Hamiltonian vector field of  $-\text{Im}h$ .

Let us explain the reason behind the choice of  $(\Omega_2, Y_2)$ . In the construction of the symplectic  $(n + 1)$ -handle we have to reconcile several aspects:

The data  $(P_2, \Omega_2, Y_2)$  has to determine the standard  $(n + 1)$ -handle: if  $\Omega_2 = \Omega_{\mathbb{R}^{2n+2}}$  then  $Y_2$  is the gradient flow of  $-\text{Re}h$  with respect to the Euclidean metric, whose dynamics determine the standard  $(n + 1)$ -handle. In lemma 2 we are going to prove that for  $\Omega_2$  of type  $(1, 1)$  at the origin, the Hamiltonian vector field  $Y_2$  has a hyperbolic singularity at  $0 \in \mathbb{C}^{n+1}$ . Therefore the flow of  $Y_2$  has both the right dynamical behavior to construct a standard  $(n + 1)$ -handle about  $0 \in \mathbb{C}^{n+1}$  and the right symplectic behavior.

The second aspect is that we want to define Lagrangian surgery along  $L$  so that it becomes equivalent to generalized Dehn surgery. Generalized Dehn twists appear in our current setting as follows: the origin  $0 \in \mathbb{C}^{n+1}$  is an isolated critical point for  $h$ . Let  $h_z$  denote the fiber  $h^{-1}(z) \cap W$ ,  $z \in \mathbb{C}$ , and let  $\Omega$  be any closed 2-form on  $W$  for which the fibers  $h_z$  are symplectic. The annihilator with respect to  $\Omega$  of the tangent space to the fibers is an Ehresmann connection for  $h: W \setminus \{0\} \rightarrow \mathbb{C}$ . Parallel transport over a path not containing the critical value  $0 \in \mathbb{C}$ , defines a symplectomorphism from the regular fiber over the starting point to the regular fiber over the ending point. Seidel proves ([36], lemma 1.10 in section 1.2) that for certain choice of closed 2-form  $\Omega_\tau$  which is Kähler near the origin and for all  $r \in \mathbb{R}^{>0} \subset \mathbb{C}$ , parallel transport of the fiber  $h_r$  over the boundary of the disk  $\overline{D}(r) \subset \mathbb{C}$  counterclockwise, is conjugated to a generalized Dehn twist supported in a given  $T(\lambda)$ . An argument using Taylor expansions shows that for symplectic forms of type  $(1, 1)$  at the origin the fibers  $h_z$  are symplectic near the origin, and therefore there is an associated symplectic parallel transport with respect to  $\Omega_2$ . Besides, symplectic parallel transport with respect to  $\Omega_2$  can be connected to symplectic parallel transport with respect to  $\Omega_\tau$ . The upshot is that symplectic parallel transport over  $\overline{D}(r) \subset \mathbb{C}$  counterclockwise with respect to  $\Omega_2$  can be isotoped to a generalized Dehn twist, which is the property we need to prove the equivalence of generalized Dehn surgery and Lagrangian surgery.

The third aspect is that we need a flexible choice of symplectic form  $\Omega_2$  on the  $(n+1)$ -handle, so the cobordisms naturally associated to Lefschetz pencil structures to be described in subsection 5.3, can be identified with Lagrangian surgery.

In the next lemma we collect some useful properties of parallel transport with respect to forms of type  $(1,1)$  at the origin:

**Lemma 2.** *Let  $\Omega \in \Omega^2(W)$  be a symplectic form of type  $(1,1)$  at the origin. Let  $Y \in \mathfrak{X}(W)$  be the Hamiltonian vector field of  $-\text{Im}h$  with respect to  $\Omega$ . Then the following holds:*

- (1)  $Y$  is a section of  $\text{Ann}(Y)^\Omega$  which vanishes at  $0 \in \mathbb{C}^{n+1}$ .
- (2)  $h_*Y(p)$  is a strictly negative multiple of  $\frac{\partial}{\partial x}$ , where  $p \in W \setminus \{0\}$ ,  $z = (x, y)$ .
- (3)  $Y$  has a non-degenerate singularity at the origin with  $n+1$  positive eigenvalues and  $n+1$  negative eigenvalues.
- (4) For each  $r \in \mathbb{R} \setminus \{0\}$  we have Lagrangian spheres  $\Sigma_r \subset h_r$  characterized as the set of points contracting into the critical point by the parallel transport over the segment  $[0, r]$ ; the spheres come with a parametrization up to isotopy and the action of  $O(n+1)$  (they are “framed”). More generally, for each  $z$  and  $\gamma$  an embedded curve joining  $z$  and the origin, the points in  $h_{\gamma(0)}$  sent to the origin by parallel transport over  $\gamma$  are a Lagrangian sphere  $\Sigma_{\gamma(0)}$ . Their construction depends smoothly on  $\Omega$  and  $\gamma$ .
- (5) For any embedded curve  $\gamma$  through the origin parallel transport

$$\rho_\gamma: (h_{\gamma(0)} \setminus \Sigma_{\gamma(0)}, \Omega) \rightarrow (h_{\gamma(1)} \setminus \Sigma_{\gamma(1)}, \Omega)$$

is a symplectomorphism possibly not everywhere defined.

*Proof.* This is a generalization of lemma 1.13 in [36] for local symplectic forms which are of type  $(1,1)$  at the origin; also -an very important for our applications- smooth dependence on the symplectic form and curve  $\gamma \subset \mathbb{C}$  is proved.

Points 1 and 2 are a straightforward calculation. Point 3 is also elementary once we use Taylor expansions at the origin.

Point 3 implies that  $0 \in \mathbb{C}^{n+1}$  is a hyperbolic singular point for  $Y$  (see [27] for basic theory on dynamical systems). Let  $W^s(Y)$  denote the stable manifold. Point 2 implies that  $[0, r_0) \subset h(W^s(Y))$  for some  $r_0 > 0$ , and that for any  $r \in (0, r_0)$  the intersection  $h_r \cap W^s(Y)$  is transverse. Since  $\Sigma_r := h_r \cap W^s(Y)$  is a hypersurface of  $W^s(Y)$  transverse to  $Y$ , it is diffeomorphic to a sphere. More precisely, the stable manifold theorem gives a parametrization  $\Psi^{\text{st}}: B^{n+1} \rightarrow W^s(Y)$  of a neighborhood of the origin inside  $W^s(Y)$  which is unique up to isotopy and the action of  $O(n+1)$ , the latter associated to the choice of an orthonormal basis of the tangent space of  $W^s(Y)$  at the origin; such parametrization induces a parametrization  $l: S^n \rightarrow \Sigma_r$  unique up to isotopy and the action of  $O(n+1)$ .

That  $\Sigma_r$  is Lagrangian follows from point 2, exactly as in the proof of lemma 1.13 in [36].

The result for any other point  $z$  and a curve  $\gamma$  joining it to the origin follows from the previous ideas applied to the Hamiltonian of  $-\text{Im}(F \circ h)$ , where  $F: \mathbb{C} \rightarrow \mathbb{C}$  is a diffeomorphism fixing the origin which sends  $\gamma$  to  $[0, r]$ , for some  $r \in \mathbb{R} \setminus \{0\}$ .

If  $\Omega_u$  is a smooth family, then the stable manifold theorem with parameters (the proof of theorem 6.2 in [27], chapter 2, is seen to depend smoothly on parameters) gives parametrizations  $\Psi_u^{\text{st}}: B^{n+1} \rightarrow W^s(Y_u)$  of neighborhoods of 0 inside the corresponding stable manifolds. This induces a smooth family of parametrizations of the Lagrangian spheres

$$l_u: S^n \rightarrow \Sigma_{u,r}.$$

Clearly there is also smooth dependence on the path  $\gamma$  if we choose diffeomorphisms  $F_\gamma: \mathbb{C} \rightarrow \mathbb{C}$  with such dependence.

Parallel transport is not defined for points in  $h_{\gamma(0)}$  which converge to the singular point  $0 \in \mathbb{C}^{n+1}$ , which by definition are the Lagrangian sphere  $\Sigma_{\gamma(0)}$ . Parallel transport may send points of  $h_{\gamma(0)} \setminus \Sigma_{\gamma(0)}$  away from  $W$ . For those points which do not leave  $W$ , which at least are those close enough to  $\Sigma_{\gamma(0)}$ , parallel transport is well known to be a symplectomorphism, and this finishes the proof of the lemma.  $\square$

4.1.2. *The shape of the symplectic  $(n+1)$ -handle.* A parametrized sphere  $L \subset M$  together with a framing determine a diffeomorphism  $\phi: H \rightarrow S^n \times \overline{B^{n+1}}(1)$ , where  $H$  is a compact neighborhood of  $L$  and  $S^n \times \overline{B^{n+1}}(1)$  is seen as a subset of the boundary of the standard  $(n+1)$ -handle

$$\overline{B^{n+1}}(1) \times \overline{B^{n+1}}(1) \subset \mathbb{R}^{n+1} \times \mathbb{R}^{n+1} = \mathbb{C}^{n+1}.$$

The diffeomorphism determines the manifold with corners

$$M \#_{\phi} \overline{B^{n+1}}(1) \times \overline{B^{n+1}}(1).$$

A way to smoothen the corners uses the gradient flow  $Y$  of  $-\text{Re}h$  with respect to the Euclidean metric: let us consider a function

$$f: H \setminus L \cong S^n \times \overline{B^{n+1}}(1) \setminus S^n \times \{0\} \rightarrow \mathbb{R}^+$$

supported in the interior of  $H$ , and such that near the attaching sphere  $L \cong S^n \times \{0\}$  its value is the time needed to flow from  $H$  to a neighborhood of  $L' \cong \{0\} \times S^n \subset \overline{B^{n+1}}(1) \times S^n$ . Then

$$M' = M \setminus H \cup \Phi_1^{fY}(H \setminus L) \cup L'$$

is a smoothening of the new boundary of the cobordism. Actually, one equally thinks of using as modified handle the region bounded by  $H$  and  $\Phi_1^{fY}(H \setminus L) \cup L'$ .

We now proceed to define smoothenings of the standard  $(n+1)$ -handle using  $Y_2$ , which is our symplectic replacement for the gradient flow of  $-\text{Re}h$ . For the sake of flexibility in the definition of Lagrangian surgery we make the construction depend on a small enough parameter  $r > 0$ .

We start by introducing some notation: the complex coordinate of  $\mathbb{C}$  is  $z = (x, y)$ . For any  $r, a, b \in \mathbb{R}$ , we let  $y_r(a, b), x_r(a, b) \subset \mathbb{C}$  be the “vertical” and “horizontal” segments joining the points  $(r, a)$  and  $(r, b)$ , and  $(a, r)$  and  $(b, r)$  respectively.

Let us consider  $r_0 > 0$  small enough so that the neighborhood  $(W, \Omega_2)$  of  $0 \in \mathbb{C}^{n+1}$  contains all Lagrangian spheres  $\Sigma_r$ ,  $r \in [-r_0, 0) \cup (0, r_0]$ , described in point 4 in lemma 2. We fix  $\epsilon > 0$  small enough and define for all  $r \in (0, r_0]$

$$H_{2,r} := h^{-1}(y_r(-\epsilon, \epsilon)), H_{2,-r} := h^{-1}(y_{-r}(-\epsilon, \epsilon)).$$

By point 2 in lemma 2  $Y_2 \pitchfork H_{2,r}, H_{2,-r}$ , so both hypersurfaces inherit 2-calibrated foliations. By definition of the symplectic connection, the leaves of these 2-calibrated foliations are exactly the symplectic fibers of  $h: H_{2,r} \rightarrow y_r(-\epsilon, \epsilon)$  and  $h: H_{2,-r} \rightarrow y_{-r}(-\epsilon, \epsilon)$ .

The Lagrangian sphere  $\Sigma_r$  is going to be the attaching sphere of the  $(n+1)$ -handle, and therefore we need to specify an isotopy class of parametrizations (its framing is the Lagrangian framing): if  $\Omega_2 = \omega_{\mathbb{R}^{2n+2}} = \sum_{i=1}^{n+1} dx_i \wedge dy_i$ , then the Lagrangian sphere over  $(r_0, 0)$  is the sphere radius  $\sqrt{r_0}$  in the coordinates  $x$

$$\{(x, 0) \in \mathbb{R}^{2n+2} \mid x_1^2 + \dots + x_{n+1}^2 = r_0\}.$$

Remark that the Lagrangian framing is the standard framing. The subset of forms of type  $(1, 1)$  at the origin is convex and hence connected (the symplectic condition holds for the segment close enough to the origin). We choose any path  $\zeta$  connecting  $\omega_{\mathbb{R}^{2n+2}}$  to  $\Omega_2$ , and lemma 2 with parameter space  $\zeta$  allows us to transfer the canonical parametrization of the sphere of radius  $\sqrt{r_0}$  to a parametrization  $l$  of  $\Sigma_{r_0}$ . This completely determines the isotopy class of  $l$ .

To connect the hypersurfaces  $H_{2,r}$  and  $H_{2,-r}$  we want a careful parametrization of a neighborhood of  $\Sigma_r$  inside  $H_{2,r}$ ,  $r \in (0, r_0]$ . Let us extend the parametrization of  $\Sigma_{r_0}$  to a neighborhood of  $\Sigma_r$  inside its leaf

$$\varphi_{r_0} : (U, \Omega_{\mathcal{F}}) \rightarrow (T(\lambda), d\alpha_{\text{can}}).$$

Parallel transport over the horizontal segment  $x_0(r_0, r)$  induces a parametrization of a neighborhood of  $\Sigma_r$  inside its leaf

$$\varphi_r := \varphi_{r_0} \circ \rho_{x_0(r_0, r)} : (\rho_{x_0(r_0, r)}^{-1}(U), \Omega_{\mathcal{F}}) \rightarrow (T(\lambda), d\alpha_{\text{can}}), \quad r \in (0, r_0]. \quad (8)$$

We define  $T_r(\lambda) := \varphi_r^{-1}(T(\lambda))$ ,  $r \in (0, r_0]$ .

Let  $R_r$  be the (negative) Reeb vector field on  $H_{2,r}$  determined by the equality  $h_*R_r = \frac{\partial}{\partial y}$ ,  $r \in (0, r_0]$ . The neighborhood of  $\Sigma_r$  inside  $H_{2,r}$  that we are going to consider is  $T_r(\lambda, \epsilon)$ , defined as in equation (5) using on  $H_{2,r}$  the flow of  $R_r$ . In fact we redefine  $H_{2,r} := T_r(\lambda, \epsilon)$ ,  $r \in (0, r_0]$ .

Let

$$f_r \in C^\infty(T_r(\lambda, \epsilon) \setminus \Sigma_r, \mathbb{R}^+) \quad (9)$$

have the following properties:

- The support of  $f_r$  is contained in the interior of  $T_r(\lambda, \epsilon)$ .
- The time 1 flow of  $f_r Y_2$  sends  $T_r(\lambda/2, \epsilon/2) \setminus \Sigma_r$  into  $H_{2,-r}$ .

We use the hypersurface

$$H_{2,r}^{\mu_L} := \Phi_1^{f_r Y_2}(T_r(\lambda, \epsilon) \setminus \Sigma_r) \cup \Sigma_{-r} \quad (10)$$

to define the handle  $P_{2,r}$  as the compact domain of  $\mathbb{C}^{n+1}$  bounded by  $H_{2,r}^{\mu_L}$  and  $H_{2,r}$ . The new boundary of the cobordism is

$$M^{\mu_L} = (M \setminus H_{2,r}) \cup H_{2,r}^{\mu_L}.$$

#### 4.1.3. Lagrangian surgery.

**Proposition 3.** *Any parametrized Lagrangian sphere  $L \subset (M^{2n+1}, \mathcal{F}, \omega)$ ,  $n > 1$ , determines symplectic elementary cobordisms  $(Z, \Omega)$  carrying a symplectic vector field transverse to the boundary, which induce 2-calibrated foliations*

$$(M, \mathcal{F}, \omega), (M^{\mu_L}, \mathcal{F}^{\mu_L}, \omega^{\mu_L}).$$

*Proof.* Any form of type (1, 1) at the origin endows the  $(n+1)$ -handle  $P_{2,r}$  with a symplectic structure  $\Omega_2$ . The Hamiltonian vector field  $Y_2$  is transverse to  $\partial P_{2,r}$  and determines a parametrized Lagrangian sphere  $\Sigma_r$ . The parametrized Lagrangian sphere  $\Sigma_r$  with its Lagrangian framing is isotopic to the standard sphere with its standard framing. Therefore applying corollary 1 produces the elementary cobordism  $Z$ . Moreover, it gives rise to a symplectic structure  $\Omega$  and a symplectic vector field  $Y$  transverse to  $\partial Z$  which induce a 2-calibrated foliation on  $\partial Z = M \amalg M^{\mu_L}$ . By construction we recover  $(\mathcal{F}, \omega)$  on  $M$  and obtain  $(\mathcal{F}^{\mu_L}, \omega^{\mu_L})$  on  $M^{\mu_L}$  which coincides with  $(\mathcal{F}, \omega)$  away from a neighborhood of  $L$ .  $\square$

**Definition 6.** *Let  $L \subset (M^{2n+1}, \mathcal{F}, \omega)$ ,  $n > 1$ , be a parametrized Lagrangian sphere. We define Lagrangian surgery along  $L$  as any of the 2-calibrated foliations  $(M^{\mu_L}, \mathcal{F}^{\mu_L}, \omega^{\mu_L})$  in proposition 3, obtained as the new boundary component of the symplectic elementary cobordism which amounts to attaching a symplectic  $(n+1)$ -handle as described in 4.1.1, 4.1.2 to the trivial symplectic cobordism determined by  $(M, \mathcal{F}, \omega)$ .*

**Remark 5.** *Instead of gluing the  $(n+1)$ -handle to the trivial cobordism we can proceed the other way around. This amounts to reversing the co-orientation on*



$(M, \mathcal{F}, \omega)$  and hence considering on the  $(n+1)$ -handle the opposite symplectic vector field  $\text{Im}h$ . Actually, we can do things in an equivalent way: on the  $(2n+2)$ -dimensional  $(n+1)$ -handle we can use as attaching sphere  $\Sigma_{-r}$  instead of  $\Sigma_r$ ,  $r > 0$  (and also choosing an appropriate shape for the handle). We go from this second point of view to the first one by using the symplectic transformation  $(z_1, \dots, z_{n+1}) \mapsto (-iz_1, \dots, -iz_{n+1})$ . It can be checked that the new boundary is a 2-calibrated foliation

$$(M^{-\mu_L}, \mathcal{F}^{-\mu_L}, \omega^{-\mu_L}). \quad (11)$$

Surgery along  $L$  with framing  $\mu_{L-}$  gives (11) with opposite orientation.

4.1.4. *Independence on choices.* In the construction of  $(M^{\mu_L}, \mathcal{F}^{\mu_L}, \omega^{\mu_L})$  there are several choices both in the symplectic handle and in the trivial cobordism, which in principle may result into non-equivalent 2-calibrations  $\omega^{\mu_L}$ . The choices in the symplectic handle are the symplectic form  $\Omega_2$ , the parameter  $r \in (0, r_0]$  ( $r_0$  itself depends on  $\Omega_2$ ), the function  $f_r$  (this including the choice of  $\epsilon > 0$ ) and the parametrization  $\varphi_{r_0}$ . Choices in the trivial cobordism correspond to choices in  $H_1$ . There, we have a fixed  $l^{-1}: L \rightarrow S^n$  and we choose an extension  $\varphi: (U, \omega_{\mathcal{F}}) \rightarrow (T(\lambda), d\alpha_{\text{can}})$  and a Reeb vector field  $R_1$ . When applying corollary 1 to construct the elementary cobordism  $Z$ , the choice of extension  $\varphi_{r_0}$  is absorbed into the choice of extension  $\varphi$ .

In theorem 4 we will show that for all  $r > 0$  small enough Lagrangian surgery produces a 2-calibrated foliation equivalent to generalized Dehn surgery. Since according to proposition 2 generalized Dehn surgery is independent of the extension  $\varphi$  and of the Reeb vector field, we just need to prove independence of Lagrangian surgery on the function  $f_r$  and the parameter  $r$ . Note that these two choices do not matter for the diffeomorphism type of  $(M^{\mu_L}, \mathcal{F}^{\mu_L})$ . The key technical result that provides the required flexibility in our Poisson setting, is an extension result for symplectomorphisms (lemma 3).

Let us first address the case when all choices are the same except for the functions  $f_r, f'_r$  in equation (9). They give rise to two hypersurfaces  $H_{2,r}^{\mu_L}(f_r), H_{2,r}^{\mu_L}(f'_r)$  as described in equation (10), transverse to  $Y_2$  and matching near their boundary and near  $\Sigma_{-r}$ . Following the flow lines of  $Y_2$  defines a compactly supported diffeomorphism from  $H_{2,r}^{\mu_L}(f_r)$  to  $H_{2,r}^{\mu_L}(f'_r)$ . The diffeomorphism is a Poisson equivalence because by construction it is symplectic parallel transport over horizontal segments. Therefore the extension by the identity is a Poisson equivalence between the 2-calibrated foliations associated to  $f_r$  and  $f'_r$ . The general position argument used in the proof of theorem 3 implies that this is in fact an equivalence of 2-calibrated foliations.

The case where the only different choice is  $r < r'$  is more delicate. We want to construct a Poisson equivalence

$$\phi: (M^{\mu_L}, \mathcal{F}^{\mu_L}, \omega_r^{\mu_L}) \rightarrow (M^{\mu_L}, \mathcal{F}^{\mu_L}, \omega_{r'}^{\mu_L})$$

which extends the identity map in the complement of  $H_{2,r}^{\mu_L} \subset M^{\mu_L}$ . Let us define  $\phi_1: H_{2,r}^{\mu_L} \rightarrow H_{2,r'}^{\mu_L}$  to be the map given by the flow lines of  $Y_2$ , which we just saw corresponds to symplectic parallel transport over horizontal segments. It is well defined near  $\Sigma_{-r}$  because for points in  $\Sigma_{-r} \subset H_{2,r}^{\mu_L}$  we make parallel transport over the segment  $x_0(-r, -r')$ , which does not contain the origin.

We need to introduce the following annular subsets around the Lagrangian sphere  $\Sigma_r$ ,  $r \in (0, r_0]$ :

$$A_r(\lambda, \lambda') := T_r(\lambda) \setminus \text{int}T_r(\lambda'), \lambda > \lambda' > 0,$$

$$A_r(\lambda, \lambda', \epsilon, \epsilon') := T_r(\lambda, \epsilon) \setminus \text{int}T_r(\lambda', \epsilon'), \lambda > \lambda' > 0, \epsilon > \epsilon' > 0.$$

The boundary of an annular subset is made of an inner and an outer connected component, according to their distance to the Lagrangian sphere (figure 2).

Let  $\lambda', \epsilon' > 0$  be such that the support of  $f_r$  (respectively  $f_{r'}$ ) does not intersect  $A_r(\lambda, \lambda', \epsilon, \epsilon')$  (respectively  $A_{r'}(\lambda, \lambda', \epsilon, \epsilon')$ ). Therefore  $A_r(\lambda, \lambda', \epsilon, \epsilon') \subset H_{2,r}^{\mu L} \cap H_{2,r}$  (respectively  $A_{r'}(\lambda, \lambda', \epsilon, \epsilon') \subset H_{2,r'}^{\mu L} \cap H_{2,r'}$ ) and on  $A_r(\lambda, \lambda', \epsilon, \epsilon')$

$$\phi_1(p) = \rho_{x_{y(h(p))}}(r, r')(p). \quad (12)$$

Note that  $\phi_1$  does not extend to the identity map on

$$M^{\mu L} \setminus T_r(\lambda', \epsilon') \subset M \rightarrow M^{\mu L} \setminus T_r(\lambda', \epsilon') \subset M.$$

The problem is that according to the parametrizations of  $T_r(\lambda, \epsilon)$  and  $T_{r'}(\lambda, \epsilon)$  described in the paragraph following equation (8), the identity map corresponds to

$$\phi_2(p) := \rho_{y_{r'}(0, y(h(p)))} \circ \rho_{x_0(r, r')} \circ \rho_{y_r(y(h(p)), 0)}(p). \quad (13)$$

In addition  $\phi_1$  may not be everywhere defined since  $\phi_1(A_r(\lambda, \lambda', \epsilon, \epsilon'))$  can fail to be contained in  $A_{r'}(\lambda, \lambda', \epsilon, \epsilon') \subset H_{2,r'} \cap H_{2,r}^{\mu L} \subset M^{\mu L}$ .

Let us assume the existence of  $[\lambda_1, \lambda'_1] \subset [\lambda, \lambda']$  and

$$\phi_3 : A_r(\lambda_1, \lambda'_1, \epsilon, \epsilon') \rightarrow A_{r'}(\lambda, \lambda', \epsilon, \epsilon')$$

a Poisson diffeomorphism onto its image, which equals  $\phi_1$  (respectively  $\phi_2$ ) near the inner (respectively outer) boundary of  $A_r(\lambda_1, \lambda'_1, \epsilon, \epsilon')$ . Then

$$\phi := \begin{cases} \phi_1 & \text{in } H_{2,r}^{\mu L} \setminus A_r(\lambda_1, \lambda'_1, \epsilon, \epsilon'), \\ \phi_3 & \text{in } A_r(\lambda_1, \lambda'_1, \epsilon, \epsilon'), \\ \text{Id} & \text{in } M^{\mu L} \setminus (H_{2,r}^{\mu L} \cap T_r(\lambda_1, \epsilon)) \end{cases}$$

is clearly an equivalence between  $(M^{\mu L}, \mathcal{F}^{\mu L}, \omega_r^{\mu L})$  and  $(M^{\mu L}, \mathcal{F}^{\mu L}, \omega_{r'}^{\mu L})$ .

The construction of  $\phi_3$  requires the following basic result on extension of symplectic transformations, which is going to be also crucial to prove the equivalence of Lagrangian and generalized Dehn surgery.

**Lemma 3.** *Let  $\varsigma_j : A(\lambda, \lambda') \subset (T(\lambda), d\alpha) \rightarrow (T^*S^n, d\alpha)$ ,  $j = 1, 2$ ,  $n > 1$ , be symplectic diffeomorphisms onto their image with the following properties:*

- (1) *There exists  $[\lambda_1, \lambda'_1] \subset [\lambda, \lambda']$  such that  $\sigma_1 := \varsigma_2^{-1} \circ \varsigma_1$  is defined on  $A(\lambda_1, \lambda'_1)$  and there exists  $\sigma_s : A(\lambda_1, \lambda'_1) \rightarrow (T^*S^n, d\alpha)$ ,  $s \in [0, 1]$ , an isotopy connecting the identity to  $\sigma_1$  and satisfying  $\sigma_s(A(\lambda_1, \lambda'_1)) \subset A(\lambda, \lambda')$  for all  $s \in [0, 1]$ .*
- (2) *They isotopy  $\sigma_s$  is Hamiltonian.*

*Then there exists  $\varsigma : (A(\lambda, \lambda'), d\alpha) \rightarrow (T^*S^n, d\alpha)$  a symplectic diffeomorphism onto its image, which coincides with  $\varsigma_1$  (respectively  $\varsigma_2$ ) near the inner (respectively outer) boundary of  $A(\lambda, \lambda')$ ; moreover, if the  $C^0$ -norm of  $\sigma_s$  is small enough, then  $\varsigma$  sends  $A(\lambda_1, \lambda'_1)$  into  $A(\lambda, \lambda)$ .*

*In case  $\varsigma_j$ ,  $j = 1, 2$ , the radii  $\lambda, \lambda'$ , the isotopy  $\sigma_s$  and the symplectic form  $d\alpha$  depend on a smooth parameter,  $\varsigma$  can be arranged to depend smoothly on the parameter.*

*Proof.* Let us define

$$V = \bigcup_{s \in [0, 1]} \sigma_s(A(\lambda_1, \lambda'_1)) \times \{s\} \subset T^*S^n \times [0, 1].$$

Its inner (respectively outer) boundary is by definition the union of the inner (respectively outer) boundaries of  $\sigma_s(A(\lambda_1, \lambda'_1))$ .

Condition 1 implies  $V \subset A(\lambda, \lambda') \times [0, 1]$ . Let  $X$  be the vector field on  $V$  whose flow after projection on  $T^*S^n \times \{0\}$  gives the isotopy  $\sigma_s$ . Let  $\beta_s = i_{X_s} d\alpha$ . Since  $\sigma_s$  is Hamiltonian there exists a (time dependent) Hamiltonian  $F \in C^\infty(V)$  such that  $dF_s = \beta_s$  and  $F_0 = 0$ .

Because  $\sigma_s$  in an isotopy, for each  $s \in [0, 1]$  the subset

$$A(\lambda, \lambda') \setminus \sigma_s(A(\lambda_1, \lambda'_1))$$

has an outer connected component  $C_{o,s}$  (containing the outer boundary of  $A(\lambda, \lambda')$ ) and an inner connected component  $C_{i,s}$ . We define

$$\tilde{V} = \bigcup_{s \in [0,1]} (\sigma_s(A(\lambda_1, \lambda'_1)) \cup C_{o,s}) \times \{s\} \subset A(\lambda, \lambda') \times [0, 1].$$

Let  $\tilde{F} \in C^\infty(\tilde{V})$  be a function which coincides with  $F$  near the inner boundary of  $V$ , is supported inside  $V$  and vanishes for  $s = 0$ . Then the time 1 flow of the path of Hamiltonian vector fields of  $\tilde{F}$  composed with  $\varsigma_2$ , is a symplectomorphism which coincides with  $\varsigma_1$  (respectively  $\varsigma_2$ ) near the inner (respectively outer) boundary of  $A(\lambda, \lambda'_1)$ . The lemma is proved once we extend the symplectomorphism to  $A(\lambda, \lambda')$  by using  $\varsigma_1$  on  $A(\lambda'_1, \lambda')$ .

It is also clear that if the  $C^0$ -norm of the isotopy is arbitrarily small, we can pick  $\hat{\lambda}_1 < \lambda_1$  so that  $\sigma_s((A(\hat{\lambda}_1, \lambda'_1))) \subset A(\lambda_1, \lambda')$ , and therefore  $\varsigma(A(\lambda_1, \lambda'_1)) \subset A(\lambda, \lambda')$ .  $\square$

**Remark 6.** *There is an analogous symplectic extension result when  $\varsigma_j$ ,  $j = 1, 2$ , are defined on  $T(\lambda)$ . Under assumption 1 (with domain  $T(\lambda_1)$  instead of  $A(\lambda_1, \lambda'_1)$ ), the outcome is  $\varsigma$  a symplectomorphism which matches  $\varsigma_1$  in a neighborhood of  $T(\lambda')$  and  $\varsigma_2$  near the boundary of  $T(\lambda)$ . If the  $C^0$ -norm of the isotopy is small enough, then we can assume as well  $\varsigma(T(\lambda_1)) \subset T(\lambda)$ .*

We are going to apply lemma 3 in several instances in which the isotopy  $\sigma_s$  is defined by symplectic parallel transport over curves  $\gamma_s$ . To that end we are going to recall a straightforward result to control the  $C^0$ -norm of  $\sigma_s$ . Before that we need to introduce some notation. Given curves  $\gamma_1, \dots, \gamma_n \subset \mathbb{C}$  parametrized by the interval and such that  $\gamma_l(1) = \gamma_{l+1}(0)$ ,  $l = 1, \dots, n-1$ , their concatenation is the piecewise smooth curve

$$\gamma_1 * \dots * \gamma_n, v \in [(l-1)/n, l/n] \mapsto \gamma_l(n(v - (l-1)/n)), l = 1, \dots, n-1.$$

If we speak of a family of piecewise smooth curves, it is understood that all the curves can be written as concatenation of the same number of curves and the family is smooth on each of the intervals.

Once we have fixed a symplectic form  $\Omega$  on a neighborhood  $W$  of the origin which makes the fibers of the quadratic form  $h$  symplectic, any piecewise smooth curve  $\gamma \subset \mathbb{C}$  inside the image of  $h$  induces by parallel transport a symplectomorphism  $\rho_\gamma$ , which in general is not everywhere defined on  $h_{\gamma(0)}$  (both for points converging to the critical points and for points escaping  $W$ ): we just need to pull back the symplectic fibration  $f: (W \setminus \{0\}, \Omega) \rightarrow \mathbb{C} \setminus \{0\}$ , and follow over each smooth piece of the curve the 1-dimensional kernel of the closed 2-form induced on the pullback fibration. From now on and unless otherwise stated, by a curve  $\gamma \subset \mathbb{C}$  we will mean a piecewise smooth curve such that on each smooth interval it is either constant or embedded. In this way (i) we can define horizontal lifts of  $\gamma$  without using pullback bundles, and (ii) on each smooth interval  $\gamma$  is the integral curve of a locally defined vector field. These two properties will make our proofs more transparent.

We also recall that  $A_{r,t}(\lambda, \lambda')$ ,  $r \in (0, r_0]$ ,  $t \in [-\epsilon, \epsilon']$ , stands for the time  $t$  Reeb flow of  $A_r(\lambda, \lambda')$ , where the Reeb vector field is  $R_r$ . If we let  $\tilde{Y}$  denote the horizontal lift of  $\frac{\partial}{\partial y}$ , then  $R_r = \tilde{Y}$ . Then we also define  $A_{0,t}(\lambda, \lambda') := \Phi_t^{\tilde{Y}}(A_0(\lambda, \lambda'))$  ( $A_0(\lambda, \lambda')$  itself well defined because  $A_{r_0}(\lambda, \lambda') \cap \Sigma_{r_0}$  is empty).

**Lemma 4.** *Let  $\kappa_{t,s} \subset \mathbb{C}$ ,  $t \in [\delta, \delta']$ ,  $s \in [0, 1]$ , be a family of loops. Let  $\gamma_{t,s,l}$  be a sequence of families of loops converging to  $\kappa_{t,s}$  in the  $C^1$ -norm uniformly on  $t, s$ .*

If the horizontal lifts  $\tilde{\kappa}_{t,s}$  starting at  $A_{r,t}(\lambda, \lambda')$  are defined for all  $v \in [0, 1]$  (the lift neither converges to  $0 \in \mathbb{C}^{n+1}$  nor leaves  $W$ ), then the following holds:

- (1) As  $l$  tends to infinity we have convergence

$$\rho_{\gamma_{t,s,l}} \xrightarrow{C^0} \rho_{\kappa_{t,s}}$$

on  $A_{r,t}(\lambda, \lambda')$  uniformly on  $t, s$ ;

- (2) For any fixed  $t$  if  $\rho_{\kappa_{t,0}}, \rho_{\gamma_{t,0,l}}$  are the identity map,  $\gamma_{t,s,l}$  does not intersect the origin and the homotopies  $\gamma_{t,s,l}$  converge to the homotopy  $\kappa_{t,s}$  in the  $C^2$ -norm, then  $\rho_{\kappa_{t,s}}$  is a Hamiltonian isotopy.

*Proof.* Recall that  $\rho_{\kappa_{t,s}} = \tilde{\kappa}_{t,s}(1)$ . Let  $K$  be the union of the horizontal lifts  $\tilde{\kappa}_{t,s}$  starting at all  $p \in A_{r,t}(\lambda, \lambda')$  for all  $t, s$ . By assumption  $K \subset W$  is a compact subset not containing the critical point  $0 \in \mathbb{C}$ . Then we can work inside  $U_K \subset W$  a compact neighborhood of  $K$  missing the critical point, where the convergence in point 1 follows from basic ODE theory.

If  $n = 2$  then  $\kappa_{t,s}$  may not be Hamiltonian because  $A_{r,t}(\lambda, \lambda')$  has non-trivial first Betti number. If  $\gamma_{t,s,l}$  does not contain the origin, then parallel transport cannot converge to the critical point  $0 \in \mathbb{C}^{n+1}$ . It cannot scape  $W$  for connectivity reasons: for each fixed  $t$  and for  $l$  large enough, parallel transport  $\rho_{t,s,l}$ ,  $s \in [0, 1]$ , is an isotopy sending  $A_{r,t}(\lambda, \lambda')$  inside  $h_{\kappa_{t,s}(0)} \cap W$ . Then it must send  $T_{r,t}(\lambda)$  inside  $h_{\kappa_{t,s}(0)} \cap W$ .

Because  $T_{r,t}(\lambda)$  has trivial first Betti number  $\rho_{\gamma_{t,s,l}}$  is a Hamiltonian isotopy. Because convergence of the homotopies in the  $C^2$ -norm implies convergence of the isotopies in the  $C^1$ -norm, the closed 1-form  $\beta_s$  associated to the isotopy  $\rho_{\kappa_{t,s}}$ ,  $s \in [0, 1]$ , can be  $C^0$ -approximated by exact ones, and therefore it is exact and  $\rho_{\kappa_{t,s}}$  is Hamiltonian.  $\square$

**Remark 7.** A similar convergence result holds if the horizontal lifts start at all points in  $T_{r,t}(\lambda)$ .

We are ready to construct  $\phi_3$  on  $A(\lambda_1, \lambda'_1, \epsilon, \epsilon')$  which coincides with the Poisson morphism  $\phi_1$  in (12) (respectively  $\phi_2$  in (13)) near the inner (respectively outer) boundary of  $A(\lambda_1, \lambda'_1, \epsilon, \epsilon')$ .

Recall that  $t$  is the coordinate on the interval  $[-\epsilon, \epsilon]$  and fix  $\epsilon'' \in (\epsilon', \epsilon)$ . In a first stage we are going to apply lemma 3 to the restrictions to the  $t$ -leaf  $\phi_{1,t}, \phi_{2,t}$  with parameter space  $t \in [-\epsilon'', \epsilon'']$ : let us define

$$\gamma_{t,1} := x_t(r, r') * y_{r'}(t, 0) * x_0(r', r) * y_r(0, t).$$

By equations (12) and (13)

$$\sigma_t := \phi_{2,t}^{-1} \circ \phi_{1,t} = \rho_{\gamma_{t,1}}.$$

We let  $\sigma_{t,s} := \rho_{\gamma_{t,s}}$ , where  $\gamma_{t,s}$  is a family of curves in  $\mathbb{C}$  connecting the constant path  $(r, t)$  to  $\gamma_{t,1}$ , for example as depicted in figure 3.

To get control on the  $C^0$ -norm of  $\rho_{\gamma_{t,s}}$ , we define  $\kappa_{t,s} = y_r(t, (s-1)t) * y_r((s-1)t, t)$  and we let the family  $\gamma_{t,s}$  vary with  $r'$ , so that when  $r'$  converges to  $r$  the curves  $\gamma_{t,s}$  converge to the curves  $\kappa_{t,s}$  in the  $C^1$ -norm. Since  $\kappa_{t,s}$  does not contain the origin and  $\rho_{\kappa_{t,s}} = \text{Id}$ , by lemma 4 if  $r'$  is close enough to  $r$  then  $\rho_{\gamma_{t,s}}$  is as close as desired to the identity on  $A_{r,t}(\lambda', \lambda)$  in the  $C^0$ -norm. Remark that here we do not use the full power of lemma 4, as the curves  $\kappa_{t,s}$  do not contain the origin.

The conclusion is that for  $t \in [-\epsilon', \epsilon']$  hypothesis 1 in lemma 3 is satisfied (it is understood that we conjugate the isotopy problem in  $A_{r,t}(\lambda, \lambda')$  to an isotopy problem in  $A(\lambda, \lambda')$ , using minus the Reeb flow for time  $t$  and the chart  $\varphi_r$ ). We can perform exactly the same construction for  $|t| \in [\epsilon', \epsilon'']$  with the maps  $\rho_{\kappa_{t,s}} = \text{Id}, \rho_{\gamma_{t,s}}$  defined now on  $T_{r,t}(\lambda)$ , to conclude that the hypothesis of remark 7 is also satisfied.

Because  $\kappa_{s,t}$  does not contain  $0 \in \mathbb{C}$ , for  $r'$  close enough to  $r$  the isotopy  $\gamma_{t,s}$  misses the origin, and therefore it is a Hamiltonian isotopy. Thus we are in the hypothesis of lemma 3 and remark 6. Inspection of the proof of lemma 6 shows that the lemma and remark can be combined to produce  $\phi_{3,t}$ ,  $t \in [-\epsilon'', \epsilon'']$ , depending smoothly on  $t$  and extending  $\phi_1$  and  $\phi_2$ .

The extension for  $|t| \in [\epsilon'', \epsilon]$  is straightforward: we let  $\tilde{\sigma}_{t,s}$  be the isotopy corresponding to the Hamiltonian  $\tilde{F}_t$  in the proof of lemma 3 (rather in the proof of remark 6). We have defined  $\phi_{3,t} := \phi_{2,t} \circ \tilde{\sigma}_{t,1}$ . Let  $\beta: [\epsilon'', \epsilon] \rightarrow [0, 1]$  be orientation reversing and constant near the boundary. For  $t \in [\epsilon'', \epsilon]$  we set  $\phi_{3,t} := \phi_{2,t} \circ \sigma_{\epsilon'', \beta(s)}$ . For negative  $t$  we proceed analogously and this produces the required extension  $\phi_{3,t}$ ,  $t \in [-\epsilon, \epsilon]$ .

We have showed that Lagrangian surgery produces equivalent 2-calibrations if  $r, r'$  are close enough, which obviously implies the independence of the construction on  $r \in (0, r_0]$ .

**4.2. Generalized Dehn surgery is equivalent to Lagrangian surgery.** Equivalence of the two surgeries will remove all dependences appearing in Lagrangian surgery. The proof of the equivalence bears much resemblance to the proof of the independence of Lagrangian surgery on the parameter  $r > 0$ , though it has additional technical complications. We give a brief overview in the following paragraphs.

To construct the equivalence between  $(M^L, \mathcal{F}^L, \omega^L)$  and  $(M^{\mu L}, \mathcal{F}^{\mu L}, \omega^{\mu L})$  a Poisson diffeomorphism suffices. The morphism is defined to be the identity away from a neighborhood of the Lagrangian spheres; then -working already in the symplectic handle we used in the cobordism- following the flow lines of  $Y_2$  extends the identity to a morphism

$$\phi_2: H_{2,r} \setminus T_r(\lambda/2, \epsilon/2) \rightarrow H_{2,r}^{\mu L}.$$

For some  $\lambda' \in (\lambda/2, \lambda)$ ,  $\epsilon' \in (\epsilon/2, \epsilon)$ ,  $\phi_2$  restricts to  $A_r(\lambda', \lambda/2, \epsilon', \epsilon/2)$  to parallel transport over horizontal segments  $x_t(r, -r)$ .

Let us cut  $T_r(\lambda', \epsilon')$  along  $T_r(\lambda')$  and let  $\chi: T_r^+(\lambda') \rightarrow T_r^-(\lambda')$  be conjugated to a generalized Dehn twist supported in the interior of  $T(\lambda/2)$ . We would be done if perhaps after modifying  $\phi_2$  near the inner boundary of  $A_r(\lambda', \lambda/2, \epsilon', \epsilon/2)$ , we can extend it to a morphism

$$\phi_3: T_r^+(\lambda', \epsilon') \#_{\chi} T_r^-(\lambda', \epsilon') \rightarrow H_{2,-r} \subset H_{2,r}^{\mu L}. \quad (14)$$

Equivalently we need a pair of morphisms  $\phi_3^{\pm}: T_r^{\pm}(\lambda', \epsilon') \rightarrow H_{2,-r}$  which satisfy

$$\phi_3^+(p) = \phi_3^- \circ \chi(p), \quad p \in T_r^+(\lambda'), \quad (15)$$

and which are independent of  $t$  for  $|t|$  small, so the induced morphism  $\phi_3^+ \#_{\chi} \phi_3^-$  is smooth.

If  $\Omega_2$  was the closed 2-form  $\Omega_r$ , then  $\chi$  can be taken to be  $\rho_{\partial \bar{D}(r)}$  parallel transport over  $\partial \bar{D}(r)$  counterclockwise.

Consider the positive half disks

$$\partial \bar{D}^+(r) := \{re^{i\theta\pi} \mid 0 \leq \theta \leq 1\} \subset \mathbb{C},$$

and set  $\zeta_t = y_r(t, 0) * \partial \bar{D}^+(r) * y_{-r}(0, t)$ . Then define

$$\begin{aligned} \rho^+ : T_r^+(\lambda', \epsilon') &\longrightarrow H_{2,-r} \\ p &\longmapsto \rho_{\zeta_{y(h(p))}}(p), \end{aligned}$$

and define  $\rho^-$  on  $T_r^-(\lambda', \epsilon')$  by parallel transport over the reflection of  $\zeta_t$  in the  $x$ -axis. Then  $\rho^{\pm}$  satisfy equation (15) and therefore they induce a morphism as in equation (14). But this morphism does not match  $\phi_2$  because for the latter we do parallel transport over horizontal segments and for  $\rho^{\pm}$  we use half disks (up to composition with vertical segments). So our problem reduces to define

Poisson equivalences on  $A_r^\pm(\lambda', \lambda/2, \epsilon', \epsilon/2)$ , which extend parallel transport over  $\zeta_t$  (and its reflection in the  $x$ -axis) near the inner boundary and parallel transport over  $x_t(-r, r)$  near the outer boundary. Of course, the extensions  $\phi_3^\pm$  have to be compatible on  $A_r^\pm(\lambda', \lambda/2)$  with  $\chi$ ; because  $\chi$  is supported in the interior of  $T_r(\lambda/2)$  the extensions must coincide on  $A_r^\pm(\lambda', \lambda/2)$ . This compatibility condition is going to follow from a careful choice of the families of curves connecting  $x_r(-t, t)$  to  $\zeta_t$ . Since we will be doing parallel transport near the critical point, we will need the full power of lemma 4 to argue that we can control the norm of the isotopies we construct and hence we are in the hypothesis of the interpolation lemma.

A further technical complication appears because the symplectic form  $\Omega_2$  in the handle is different from  $\Omega_r$ . So the extension of parallel transport over segments and half disks has to include a deformation from parallel transport with respect to  $\Omega_2$  to parallel transport with respect to  $\Omega_r$ .

**Theorem 4.** *Under the assumption  $n > 1$  we have equivalences of 2-calibrated foliations*

$$\phi: (M^L, \mathcal{F}^L, \omega^L) \rightarrow (M^{\mu L}, \mathcal{F}^{\mu L}, \omega^{\mu L}) \quad (16)$$

for all  $r > 0$  small enough.

*Proof. Stage 1.* The complement  $(M, \mathcal{F}, \omega) \setminus T_r(\lambda, \epsilon)$  can be seen as a subset of both  $(M, \mathcal{F}, \omega)$  and  $(M^{\mu L}, \mathcal{F}^{\mu L}, \omega^{\mu L})$ . We may assume without loss of generality that for some  $\lambda' > \lambda/2, \epsilon' > \epsilon/2$ , the time 1 flow of  $f_r Y_2$  sends  $T_r(\lambda', \epsilon') \setminus \Sigma_r$  into  $H_{2, -r} \subset H_{2, r}^{\mu L} \subset M^{\mu L}$ . We define

$$\phi_0 = \begin{cases} \text{Id} & \text{in } M \setminus T_r(\lambda, \epsilon), \\ \Phi_1^{f_r Y_2} & \text{in } A_r(\lambda, \lambda/2, \epsilon, \epsilon/2), \end{cases}$$

which is a Poisson morphism given on  $A_r(\lambda, \lambda/2, \epsilon', \epsilon/2)$  by parallel transport over horizontal segments  $x_t(-r, r)$ ,  $t \in [-\epsilon', \epsilon']$ .

*Stage 2.* In both  $H_{2, r}$  and  $H_{2, -r}$  we have Reeb vector fields  $R_r, R_{-r}$  defined near  $\Sigma_r$  and  $\Sigma_{-r}$  respectively (they are horizontal lifts of  $\frac{\partial}{\partial y}$ ). Their flow parametrizes the leaf spaces by  $t \in [-\epsilon, \epsilon]$ . For the purpose of checking the smoothness of the morphism  $\phi: M^L \rightarrow M^{\mu L}$  in the statement of the theorem, in this stage we shall modify  $\phi_0$  near the inner boundary of  $A_r(\lambda', \lambda/2, \epsilon', \epsilon/2)$  to make it  $t$ -invariant for  $|t|$  small (equivariant with respect to the flows of  $R_r$  and  $R_{-r}$ ).

Let  $\beta: [-\epsilon', \epsilon'] \rightarrow [-\epsilon', \epsilon']$  be an odd monotone function which is the identity near the boundary and maps to zero exactly the interval  $[-\delta, \delta]$ , with  $0 < \delta < \epsilon/2$ . Set

$$\zeta_t := y_r(t, \beta(t)) * x_{\beta(t)}(r, -r) * y_{-r}(\beta(t), t), \quad t \in [-\epsilon', \epsilon']$$

and define

$$\phi_1(p) = \rho_{\zeta_{y(h(p))}}(p), \quad p \in A_r(\lambda', \lambda/2, \epsilon', \epsilon/2),$$

which by construction is  $t$ -invariant for  $t \in [-\delta, \delta]$ .

We are going to construct  $\phi'_2: A_r(\lambda', \lambda/2, \epsilon', \epsilon/2) \rightarrow H_{2, -r}$  extending  $\phi_0$  near the outer boundary and  $\phi_1$  near the inner boundary, by applying lemma 3: let

$$\gamma_{t, s} = y_r(t, (1-s)t + s\beta(t)) * x_{(1-s)t + s\beta(t)}(r, -r) * y_{-r}((1-s)t + s\beta(t), t) * x_t(-r, r), \quad (17)$$

with  $t \in [-\epsilon', \epsilon']$ ,  $s \in [0, 1]$  and  $r \in (0, r_0]$ . Parallel transport over  $\gamma_{t, s}$  defined on  $A_{r, t}(\lambda', \lambda/2)$  connects the identity map to  $\phi_{0, t}^{-1} \circ \phi_{1, t}$ . To estimate the  $C^0$ -norm of  $\rho_{\gamma_{t, s}}$  we define  $\kappa_{t, s}$  by using the formula of  $\gamma_{t, s}$  in (17) for  $r = 0$ , and consider  $\rho_{\kappa_{t, s}}$  with domain  $A_{0, t}(\lambda', \lambda/2)$ . By construction  $\rho_{\kappa_{t, s}}$  is the identity.

Let  $\gamma'_{t, s}$  be the conjugation of  $\gamma_{t, s}$  by  $x_t(0, r)$  and let us consider  $\rho_{\gamma'_{t, s}}$  defined on  $A_{0, t}(\lambda', \lambda/2)$ , the same domain as for  $\kappa_{t, s}$ .

We construct the extension  $\phi'_{2,t}$  first for the leaves in  $[-\epsilon/2, \epsilon/2]$ : the union of the horizontal lifts  $\tilde{\kappa}_{t,s}$  at  $A_{0,t}(\lambda', \lambda/2)$  is exactly

$$K = \bigcup_{t \in [-\epsilon/2, \epsilon/2]} A_{0,t}(\lambda', \lambda/2), \quad (18)$$

a compact subset not containing the critical point  $0 \in \mathbb{C}^{n+1}$ . The curves  $\gamma'_{t,s}$  clearly converge in the  $C^1$ -norm to  $\kappa_{t,s}$  as  $r$  goes to zero. Therefore by point 1 in lemma 4 there is  $C^0$ -convergence of  $\rho_{\gamma'_{t,s}}$  to the identity.

The same result holds for  $\rho_{\gamma_{t,s}}$ , though not automatically since parallel transport over  $x_t(0, r)$  does not send  $A_{0,t}(\lambda', \lambda/2)$  diffeomorphically into  $A_{r,t}(\lambda', \lambda/2)$ . This is the same situation as in the proof of independence of Lagrangian surgery on  $r$ . We define

$$\tau_{t,s} = x_t(0, r) * y_r((t, (s-1)t) * x_{(s-1)t}(r, 0) * y_r((s-1)t, t).$$

For  $r = 0$  we get  $x_t(0, 0) * y_0(t, (s-1)t) * x_{(s-1)t}(0, 0) * y_0((s-1)t, t)$ . We consider parallel transport  $\rho_{\tau_{t,s}}$  defined on  $A_{r,t}(\lambda', \lambda/2)$ , which for  $r = 0$  is the identity. Since for  $r = 0$  the union of the horizontal lifts of  $\tau_{t,s}$  starting at  $A_{0,t}(\lambda', \lambda/2)$  is again  $K$  in (18), by point 1 in lemma 4 we conclude that  $\rho_{x_t(0,r)}(A_{0,t}(\lambda', \lambda/2))$  converges to  $A_{r,t}(\lambda', \lambda/2)$  in the  $C^0$ -norm as  $r$  tends to zero, and this finishes the proof of the estimate needed in point 1 of lemma 3 for  $t \in [-\epsilon/2, \epsilon/2]$ .

For  $|t| \in [\epsilon/2, \epsilon']$  the estimate holds by connectivity arguments already mentioned: the proof above shows that for some interval  $[\lambda'_1, \lambda'_2] \subset [\lambda', \lambda/2]$ , the isotopy  $\rho_{\gamma_{t,s}}$  sends  $A_{r,t}(\lambda'_1, \lambda'_2)$  into  $A_{r,t}(\lambda', \lambda/2)$ , for  $|t| \in [\epsilon/2, \epsilon']$ . Hence it must send  $T_{r,t}(\lambda'_1)$  into  $T_{r,t}(\lambda')$ .

The isotopies  $\rho_{\gamma_{t,s}}$  are Hamiltonian: if  $t$  is not in  $[-\delta, \delta]$ , then  $\rho_{\gamma_{t,s}}$  extends to  $T_{r,t}(\lambda')$  because  $\gamma_{t,s}$  does not contain the origin. For the remaining values of  $t$  it is easy to check that the homotopy  $\gamma_{t,s}$  can be approximated in the  $C^2$ -norm by a homotopy which does not contain  $0 \in \mathbb{C}$ . Therefore by point 2 in lemma 4 the isotopies are Hamiltonian. Hence we can apply lemma 3 and remark 6 in a compatible manner to produce  $\phi'_2$  on  $A_r(\lambda', \lambda/2, \epsilon''\epsilon/2)$ ,  $\epsilon'' \in (\epsilon/2, \epsilon')$ , extending  $\phi_0$  and  $\phi_1$ . For the  $t$ -leaves with  $|t| \in [\epsilon'', \epsilon']$ , we apply the same patching trick as in the construction of the extension  $\phi_3$  at the end of 4.1.4.

We define for  $r > 0$  small enough

$$\phi_2 = \begin{cases} \phi_0 & \text{in } M \setminus T_r(\lambda', \epsilon'), \\ \phi'_2 & \text{in } A_r(\lambda', \lambda/2, \epsilon', \epsilon/2), \end{cases}$$

which is a Poisson morphism independent of  $t \in [-\delta, \delta]$ .

*Stage 3.* In this stage we cut  $M$  along a neighborhood of  $L$  inside its leaf  $F_L$ , and then define a Poisson morphism which extends  $\phi_2$  in stage 2 and parallel transport over boundaries of half disks (“conjugated” by vertical segments); the latter parallel transport also includes a deformation from  $\Omega_2$  to  $\Omega_\tau$ .

Let us assume for the moment that  $\Omega_2$  equals  $\Omega_{\mathbb{R}^{2n+2}}$ . The closed 2-forms  $\Omega_\tau$  ([36], section 1.2) are written

$$\Omega_\tau = \Omega_{\mathbb{R}^{2n+2}} + d\alpha,$$

where  $d\alpha$  vanishes on the tangent space to the fibers  $h_z$  and is zero in a neighborhood of the union of stable and unstable manifold of  $Y_2$  with respect to  $\Omega_{\mathbb{R}^{2n+2}}$ . The first property implies that the fibers  $h_z$  are symplectic. The second property implies that symplectic parallel transport with respect to  $\Omega_\tau$  over  $x_0(r, -r)$  is defined on  $T_r(\lambda) \setminus \Sigma_r$ .

We assume that  $\alpha$  has been chosen so that parallel transport over  $\partial\bar{D}(r)$  counter-clockwise is conjugated by  $\varphi_r$  to a generalized Dehn twist supported in the interior of  $T(\lambda/2)$ . Let us define  $\Omega_u = \Omega_{\mathbb{R}^{2n+2}} + u d\alpha$ ,  $u \in [0, 1]$ , and let  $u: [0, \epsilon'] \rightarrow [0, 1]$

be a monotone function which attains the value 0 on  $[2\delta/3, \epsilon']$  and the value 1 on  $[0, \delta/3]$ .

Let us consider the arcs

$$\partial \bar{D}_t^+(r) := \{(0, t) + re^{i\theta\pi}\} \subset \mathbb{C},$$

and let us define the curves

$$\zeta_t = y_r(t, \beta(t)) * \partial \bar{D}_{\beta(t)}^+(r) * y_{-r}(\beta(t), t).$$

Next we cut  $T_r(\lambda', \epsilon')$  along  $T_r(\lambda')$  and define on  $T_r^+(\lambda', \epsilon')$

$$\phi_3(p) = \rho_{u(y(h(p))), \zeta_{y(h(p))}}(p), \quad (19)$$

which is  $t$ -invariant for  $t \in [0, \delta/3]$  and on  $T_{r,0}(\lambda')$  is parallel transport over  $\partial \bar{D}(r)^+$  counterclockwise with respect to  $\Omega_\tau$ , and therefore conjugated to a Dehn twist supported in the interior of  $T(\lambda/2)$ . We stress that this is a Poisson morphism because the restriction of  $\Omega_u$  to fibers of  $h$  is independent of  $u$  (of course what changes is the symplectic connection).

We address now the construction of  $\phi_3^+$  on  $A_r^+(\lambda', \lambda/2, \epsilon', \epsilon/2)$  a Poisson morphisms extending  $\phi_2$  and  $\phi_3$  and  $t$ -invariant for  $t \in [0, \delta/3]$ , using the same pattern as in stage 2.

Let us define the curves

$$\gamma_{t,s} = y_r(t, \beta(t)) * x_{\beta(t)}(r, sr) * \partial \bar{D}_{\beta(t)}^+(sr) * x_{\beta(t)}(-sr, r) * y_r(\beta(t), t), \quad (20)$$

for  $t \in [0, \epsilon']$  and  $s \in [0, 1]$  (see figure 4). We have

$$\phi_{\gamma_{t,1}} = \phi_{2,t}^{-1} \circ \phi_{3,t}, \quad \phi_{\gamma_{t,0}} = \text{Id}.$$

Smoothness of  $\rho_{u(t), \gamma_{t,s}}$  for  $s = 0$  may not be evident.

**Lemma 5.** *The map  $\rho_{u(t), \gamma_{t,s}}$  depends smoothly on  $t, s$ .*

*Proof.* We rewrite  $\rho_{u(t), \gamma_{t,s}}$  using vector fields on  $\mathbb{C}$  whose integral curves are the pieces whose concatenation defines  $\gamma_{t,s}$ . Let

$$X := \frac{\partial}{\partial x}, \quad Y := \frac{\partial}{\partial y}, \quad \Theta_{r,t} := rx \frac{\partial}{\partial y} - (r(y-t)) \frac{\partial}{\partial x}, \quad t \in \mathbb{R},$$

be vector fields on  $\mathbb{C}$ . Let  $\tilde{X}_u, \tilde{Y}_u, \tilde{\Theta}_{u,r,t} \in \mathfrak{X}(W \setminus \{0\})$  be their horizontal lifts with respect to the symplectic connection defined by  $\Omega_u$ . The flows  $\Phi_l^{\tilde{X}_u}, \Phi_l^{\tilde{Y}_u}, \varphi_l^{\tilde{\Theta}_{u,r,t}}$  are smooth in  $u, r, t, l$ . It follows that

$$\rho_{u(t), \gamma_{t,s}} = \tilde{\Phi}_{t-\beta(t)}^{\tilde{Y}_u(t)} \circ \tilde{\Phi}_{(s+1)r}^{\tilde{X}_u(t)} \circ \tilde{\Phi}_\pi^{\tilde{\Theta}_{u(t),sr,\beta(t)}} \circ \tilde{\Phi}_{(1-s)r}^{-\tilde{X}_u(t)} \circ \tilde{\Phi}_{t-\beta(t)}^{-\tilde{Y}_u(t)},$$

and thus  $\rho_{u(t), \gamma_{t,s}}$  has smooth dependence on  $t, s$ .  $\square$

The estimate in lemma 4 is written for parallel transport with respect to a fixed symplectic form, but it can be checked that it holds true as well in case the parallel transport is with respect  $\Omega_{u(t)}$ . Let  $\kappa_{t,s}$  be as defined in (17) for  $r = 0$ . By comparing  $\rho_{u(t), \gamma_{t,s}}$  with  $\rho_{u(t), \kappa_{t,s}} = \text{Id}$  as in the previous stage (first conjugating with  $x_t(r, 0)$  to have common domain, and then showing that the estimate holds after undoing the conjugation), we get control on the  $C^0$ -norm of  $\rho_{u(t), \gamma_{t,s}}$  for  $r$  small enough. The isotopies  $\rho_{u(t), \gamma_{t,s}}$  are Hamiltonian since they can be  $C^1$ -approximated by Hamiltonian ones. Given that the isotopy  $\rho_{u(t), \gamma_{t,s}}$  is  $t$ -invariant for  $t \in [0, \delta/3]$ , choices in the proof of lemma 3 can be done to obtain for all  $r$  small enough an extension  $\phi_3^+$  on  $A_r^+(\lambda', \lambda/2, \epsilon', \epsilon/2)$  which is  $t$ -invariant for  $t \in [0, \delta/3]$ .

For  $t \in [-\epsilon', 0]$  we proceed as we did for positive values, but using the reflection of the curves  $\gamma_{t,s}$  in the  $x$ -axis. It is possible to arrange the proof of lemma 3 to produce an extension  $\phi_3^-$  on  $A_r^+(\lambda', \lambda/2, \epsilon', \epsilon/2)$  such that

- $\phi_3^-$  is  $t$ -invariant for  $t \in [-\delta/3, 0]$ ;



- $\phi_3^+ = \phi_3^-$  on  $A_{r,0}(\lambda', \lambda/2)$ .

Then we extend  $\phi_3^+$  to  $T_r^+(\lambda', \epsilon')$  by using on  $T_r^+(\lambda/2, \epsilon/2)$  the same parallel transport over  $\zeta_t$  as in (19). Likewise, we extend  $\phi_3^-$  to  $T_r^-(\lambda', \epsilon')$  by using on  $T_r^-(\lambda/2, \epsilon/2)$  parallel transport over the reflection of  $\zeta_t$  in the  $x$ -axis.

Because

$$\phi_3^+(p) = \phi_3^- \circ \chi(p), \quad p \in T_r^+(\lambda')$$

and  $\phi_3^+, \phi_3^-$  are  $t$ -invariant for  $|t|$  small, they give rise to a Poisson morphism

$$\phi_3^+ \#_{\rho_{\partial\bar{D}(r)}} \phi_3^- : T_r^+(\lambda', \epsilon') \#_{\rho_{\partial\bar{D}(r)}} T_r^-(\lambda', \epsilon') \rightarrow H_{2, -r}.$$

The equivalence of 2-calibrated foliations for all  $r > 0$  small enough is

$$\phi = \begin{cases} \phi_2 & \text{in } M^L \setminus (T_r^+(\lambda', \epsilon') \#_{\rho_{\partial\bar{D}(r)}} T_r^-(\lambda', \epsilon')), \\ \phi_3^+ \#_{\rho_{\partial\bar{D}(r)}} \phi_3^- & \text{in } T_r^+(\lambda', \epsilon') \#_{\rho_{\partial\bar{D}(r)}} T_r^-(\lambda', \epsilon'). \end{cases} \quad (21)$$

Let us now drop the assumption  $\Omega_2 = \Omega_r$ . Let  $\Omega_u$  be a path which is constant near its boundary and which connects  $\Omega_2$  to  $\Omega_{\mathbb{R}^{2n+2}}$ .

Recall that the neighborhoods  $T_r(\lambda, \epsilon)$  have been defined with respect to  $\Omega_2$ . By the parametric version of lemma 2 (more specifically by the parametric version of the stable manifold theorem), we have smooth parametrizations  $\Sigma_{u,r}$ ,  $r \in (0, r']$ . By compactness we can extend  $\varphi_{r'}$  to parametrizations

$$\varphi_{u,r'} : (T_{u,r'}(\tilde{\lambda}), \Omega_u) \rightarrow (T(\tilde{\lambda}), d\alpha_{\text{can}}).$$

Then we define the subsets  $T_{u,r}(\tilde{\lambda})$  by parallel transport of  $T_{u,r'}(\tilde{\lambda})$  over  $x_0(r', r)$  with respect to  $\Omega_u$ , and their associated parametrizations  $\varphi_{u,r} := \varphi_{u,r'} \circ \rho_{x_0(r,r')}$ . The subsets  $T_{u,-r}(\tilde{\lambda}) \setminus \Sigma_{u,-r}$  and their parametrizations are defined in the same manner.

We can assume without loss of generality that the inclusion

$$T_{u,r}(\tilde{\lambda}) \subset T_r(\lambda/2) \quad (22)$$

holds for all  $r \in (0, r']$ . This is because the parametric version of the stable manifold theorem implies that

$$\begin{aligned} T(\lambda) \times [0, r'] \times [0, 1] &\longrightarrow h_0 \\ (q, r, u) &\longmapsto \rho_{u, x_0(r', 0)}(\varphi_{u,r}^{-1}(q)) \end{aligned}$$

is continuous, where by definition  $\rho_{u, x_0(r', 0)}(p) = 0 \in \mathbb{C}^{n+1}$  for  $p \in \Sigma_{u,r}$ .

We proceed to modify both  $A_r^+(\lambda', \lambda/2, \epsilon', \epsilon/2)$  and  $\phi_3$  in (19) just for values of  $t$  in  $[0, \delta]$ : let

$$b_i : [0, \delta] \rightarrow [2\tilde{\lambda}/3, \lambda'], \quad b_o : [0, \delta] \rightarrow [\tilde{\lambda}/2, \lambda/2]$$

be monotone increasing functions which are constant on  $[0, 3\delta/4]$  and near  $\delta$ .

Let  $v : [0, \delta] \rightarrow [0, 1]$  be a orientation reversing smooth function which is constant on  $[0, \delta/2]$  and on  $[3\delta/4, \delta]$ .

We substitute  $A_{r,t}(\lambda', \lambda/2)$  by  $A_{r,t}(b_o(t), b_i(t))$  and  $\phi_{3,t}$  in (19) by

$$\tilde{\phi}_{3,t} := \rho_{0, y_{-r}(0,t)} \circ \varphi_{0,-r}^{-1} \circ \varphi_{v(t), -r} \circ \rho_{v(t), \partial\bar{D}_{\beta(t)}^+(r)} \circ \varphi_{v(t), r}^{-1} \circ \varphi_{0,r} \circ \rho_{0, y_r(t,0)}$$

defined on  $A_{r,t}(b_o(t), b_i(t))$ . Note that the modification of the symplectic form only occurs when the domain has been modified to  $A_{r,t}(2\tilde{\lambda}/3, \tilde{\lambda}/2)$ .

By the inclusion in (22) the image of  $A_{r,t}(2\tilde{\lambda}/3, \tilde{\lambda}/2)$  by  $\varphi_{v(t), r}^{-1} \circ \varphi_{0,r} \circ \rho_{0, y_r(t,0)}$  is contained in  $T_r(\lambda/2)$ . If in addition  $r > 0$  is small enough, control on the  $C^0$ -norm of  $\rho_{v(t), \partial\bar{D}_{\beta(t)}^+(r)}$  by  $r$  implies that

$$\rho_{v(t), \partial\bar{D}_{\beta(t)}^+(r)} \circ \varphi_{v(t), r}^{-1} \circ \varphi_{0,r} \circ \rho_{0, y_r(t,0)}$$

sends  $A_{r,t}(2\tilde{\lambda}/3, \tilde{\lambda}/2)$  into  $T_{u(t),-r}(\tilde{\lambda}) \setminus \Sigma_{u(t),-r}$ , so we can compose with the chart  $\varphi_{v(t),-r}$ . Therefore  $\tilde{\phi}_{3,t}$  is well defined and for  $t \in [0, \delta/2]$  we are in the situation  $\Omega_2 = \Omega_{\mathbb{R}^{2n+2}}$

Then we have to choose  $\Omega_\tau$  whose conjugation by  $\varphi_{0,r}$  ( $\Omega_0 = \Omega_{\mathbb{R}^{2n+2}}$ ) is a Dehn twist supported in the interior of  $T(\tilde{\lambda}/2)$ .

We can use the same pattern to modify the isotopy needed to apply the extension lemma with parameters (this time the radii of the annuli vary with  $t$ ). The result is an extension  $\phi_3^+$  which is  $t$ -invariant for  $t \in [0, \delta/4]$ , and which on  $A_{r,0}(2\tilde{\lambda}/3, \tilde{\lambda}/2)$  the chart  $\varphi_{0,t}$  conjugates to a Dehn twist supported on  $T(\tilde{\lambda}/2)$ .

As we did in the previous stage, we construct the extension  $\phi_3^-$  using as domain and curves the reflection of the previous data in the  $x$ -axis. Then  $\phi$  defined as in (21) is the equivalence of 2-calibrated foliations which proves the theorem.  $\square$

**Remark 8.** *Similarly, for  $n > 1$  and every  $r > 0$  small enough one constructs equivalences*

$$(\phi: -M^{L^-}, \mathcal{F}^{L^-}, \omega^{L^-}) \rightarrow (M^{-\mu L}, \mathcal{F}^{-\mu L}, \omega^{-\mu L}).$$

and

$$\phi: (M^{-L}, \mathcal{F}^{-L}, \omega^{-L}) \rightarrow (M^{\mu L^-}, \mathcal{F}^{\mu L^-}, \omega^{\mu L^-}).$$

## 5. LEFSCHETZ PENCIL STRUCTURES AND TRANSVERSE TAUT FOLIATIONS.

Let  $(M^{2n+1}, \mathcal{F}, \omega)$  be an integral 2-calibrated foliation. In this section we gather information on the intersection of a Donaldson type submanifold with the leaves of  $\mathcal{F}$  using Lefschetz pencil structures. We also describe the relation between two Donaldson type submanifolds belonging to the same Lefschetz pencil.

We start by saying a few words about how Donaldson type submanifolds  $W$  are constructed, and how the failure of standard Morse theoretic methods to describe the topology of  $W \cap F$ ,  $F \in \mathcal{F}$ , leads to the use of Lefschetz pencil structures to address this problem.

Let us fix  $J$  a leafwise almost complex structure compatible with  $\omega$ . If  $J$  is integrable then by definition  $(M, \mathcal{F}, J)$  is a Levi-flat manifold, and the line bundle  $L_\omega$  whose curvature is  $-2\pi i\omega$  is a positive CR line bundle. According to [30] large powers of  $L_\omega$  (suitably twisted) have plenty of CR sections. In particular there exist CR sections leafwise transverse to the zero section of  $L_\omega^{\otimes k}$ . The zero set of any such section is a codimension two CR submanifold, or a divisor, intersecting  $\mathcal{F}$  transversely.

In general  $J$  is not integrable. However  $L_\omega^{\otimes k} \otimes \mathbb{C}^l$  has sections  $s$  which are both close to be  $J$ -holomorphic in an appropriate sense and leafwise transverse to the zero section of  $L_\omega^{\otimes k} \otimes \mathbb{C}^l$  ([21], corollary 1.2). As a consequence  $W = s^{-1}(0)$  is a 2-calibrated submanifold of  $(M, \mathcal{F}, \omega)$  of codimension  $2l$ , and it is what we call a Donaldson type submanifold. The topology of  $W$  and the topology of  $M$  are related by a Lefschetz hyperplane type result: the section  $s$  is chosen so that  $\log s \bar{s}$  is a Morse function. By approximate  $J$ -holomorphicity the index of critical points is greater than  $n - l$ , from which the vanishing of  $\pi_i(M, W)$ ,  $0 \leq i \leq n - l - 1$ , follows ([21], corollary 1.2). In particular the common zero set of  $n - 1$  well chosen such sections of  $L_\omega^{\otimes k}$ , is  $W^3 \hookrightarrow M$  a connected Donaldson type 3-dimensional submanifold.

For any given leaf  $F$ , it is tempting to study the topology of  $W^3 \cap F$  by the same Morse theoretic methods. It is always possible to arrange the tuple  $s = (s_1, \dots, s_{n-1})$  so that the restriction of  $\log s \bar{s}^2$  to  $F$  is a Morse function. The usual Morse theoretic argument ([7] or proposition 2 in [2]) implies that critical points

have index greater than one, and therefore if  $F$  is compact (and hence  $W^3 \cap F$  is compact), then  $W^3 \cap F$  is connected. If  $F$  is not compact then the restriction of  $\log s \bar{s}^2$  to  $W^3 \cap F$  is never proper, and it is not clear how the information on index of critical points can be translated into topological information about  $W^3 \cap F$ .

A second approach to study the topology of complex manifolds is via holomorphic Morse functions and Picard-Lefschetz theory. In our setting these are Lefschetz pencil decompositions of  $(M, \mathcal{F})$  provided by ratios of suitable pairs of sections  $s_1, s_2$  of  $L_\omega^{\otimes k}$ . Very much as we did in the previous section with the complex quadratic function  $h$ , we are going to use the parallel transport associated to a Lefschetz pencil decomposition, to “reconstruct” a leaf  $F$  from its intersection with a regular fiber of the pencil (the previous section contains the analysis around a critical point of the holomorphic Morse function). This will be enough to prove theorem 1. Parallel transport is also the way to compare two regular fibers of a given Lefschetz pencil structure, showing that they differ by a sequence of generalized Dehn twists.

**5.1. Lefschetz pencil structures.** We recall the notion of Lefschetz pencil structure and the main existence result, and collect some necessary results regarding the associated leafwise parallel transport.

**Definition 7.** *Let  $x \in (M, \mathcal{F}, \omega)$ . A chart  $\varphi_x: (\mathbb{C}^n \times \mathbb{R}, 0) \rightarrow (M, x)$  is compatible with  $(\mathcal{F}, \omega)$  if it is a foliated chart, and  $\varphi_x^* \omega$  restricted to the leaf through the origin is of type  $(1, 1)$  at the origin.*

**Definition 8.** [22] *A Lefschetz pencil structure for  $(M, \mathcal{F}, \omega)$  is given by a triple  $(f, B, \Delta)$ , where  $B \subset M$  is a codimension four 2-calibrated submanifold and*

$$f: M \setminus B \rightarrow \mathbb{C}\mathbb{P}^1$$

*is a smooth map such that:*

- (1)  *$f$  is a leafwise submersion away from  $\Delta$ , a 1-dimensional manifold transverse to  $\mathcal{F}$  where the restriction of the differential of  $f$  to  $\mathcal{F}$  vanishes. The fibers of the restriction of  $f$  to  $M \setminus (B \cup \Delta)$  are 2-calibrated submanifolds.*
- (2) *Around any critical point  $c \in \Delta$  there exist Morse coordinates  $z_1, \dots, z_n, t$  compatible with  $(\mathcal{F}, \omega)$ , and a standard complex affine coordinate on  $\mathbb{C}\mathbb{P}^1$  such that*

$$f(z, t) = z_1^2 + \dots + z_n^2 + \sigma(t), \quad (23)$$

*where  $\sigma \in C^\infty(\mathbb{R}, \mathbb{C})$ .*

- (3) *Around any base point  $b \in B$  there exist coordinates  $z_1, \dots, z_n, t$  compatible with  $(\mathcal{F}, \omega)$ , and a standard complex affine coordinate on  $\mathbb{C}\mathbb{P}^1$  such that  $B \equiv z_1 = z_2 = 0$  and  $f(z, t) = z_1/z_2$ .*
- (4)  *$f(\Delta)$  is an immersed curve in general position.*

For each regular value  $z \in \mathbb{C}\mathbb{P}^1 \setminus f(\Delta)$ , the regular fiber is the compactification  $W_z := f^{-1}(z) \cup B$ , which is a (compact) 2-calibrated submanifold.

**Theorem 5** ([22], theorem 1.2). *Let  $(M, \mathcal{F}, \omega)$  be an integral 2-calibrated foliation and let  $e$  be an integral lift of  $[\omega]$ . Then for all  $k \gg 1$  there exist Lefschetz pencils  $(f_k, B_k, \Delta_k)$  such that:*

- (1) *The regular fibers are Poincaré dual to  $ke$ .*
- (2) *The inclusion  $l_k: W_k \hookrightarrow M$  induces maps  $l_{k*}: \pi_i(W_k) \rightarrow \pi_i(M)$  (resp.  $l_{k*}: H_i(W_k; \mathbb{Z}) \rightarrow H_i(M; \mathbb{Z})$ ) which are isomorphism for  $i \leq n - 2$  and epimorphisms for  $i = n - 1$ .*

5.1.1. *Leafwise symplectic parallel transport.* Let  $(f, B, \Delta)$  be a Lefschetz pencil structure for  $(M, \mathcal{F}, \omega)$ . Away from the union of base points and critical points  $B \cup \Delta$ , the fibers of  $f$  are 2-calibrated submanifolds. In particular for any point  $p \notin B \cup \Delta$  this is equivalent to the tangent space of the leaf through  $p$  and the tangent space to the fiber of  $f$  through  $p$  intersecting transversely in a symplectic subspace. Therefore the leafwise symplectic orthogonals to the fibers define an Ehresmann connection for  $f$ , which we denote by  $\mathcal{H}$  and also refer to as the horizontal distribution.

The Ehresmann connection  $\mathcal{H}$  is defined in the non-compact manifold  $M \setminus (B \cup \Delta)$ . We are going to show that we have good control on parallel transport near base points and critical points.

Let  $F$  be a leaf of the foliation. Let  $B_F$  (respectively  $\Delta_F$ ) denote the codimension four (respectively dimension zero) submanifold of base (respectively critical) points in  $F$ . The image  $f(\Delta_F)$  is a possibly countable collection of points in the immersed curve  $f(\Delta)$ . In particular it is easy to construct curves  $\gamma \subset \mathbb{C}\mathbb{P}^1$  which do not intersect  $f(\Delta_F)$  (or to homotope curves to avoid  $f(\Delta_F)$ ).

**Lemma 6.** *Let  $\gamma \subset \mathbb{C}\mathbb{P}^1$  be curve not intersecting  $f(\Delta_F)$ . Then parallel transport  $\rho_\gamma: f_{\gamma(0)}^{-1} \cap F \rightarrow f_{\gamma(1)}^{-1} \cap F$  is a well defined symplectomorphism. Moreover, it extends smoothly to a symplectomorphism  $\rho_\gamma: W_{\gamma(0)} \cap F \rightarrow W_{\gamma(1)} \cap F$  which is the identity on  $B_F$ . In particular if  $\gamma$  misses  $f(\Delta)$ , it induces an equivalence of 2-calibrated foliations*

$$\rho_\gamma: W_{\gamma(0)} \rightarrow W_{\gamma(1)}$$

which is the identity on  $B$ .

*Proof.* A standard procedure in this situation is to blow up  $B$  along its leafwise almost complex normal directions.

We consider the following model for the blow up as a submanifold of  $M \times \mathbb{C}\mathbb{P}^1$ : we let  $\tilde{M}$  be the union of the graph of  $f$  and  $B \times \mathbb{C}\mathbb{P}^1$ . We need to show that  $\tilde{M}$  is a submanifold around points in  $B \times \mathbb{C}\mathbb{P}^1$ .

Around a point  $b \in B$  theorem 5 provides coordinates  $z_1, \dots, z_n, t$  and a standard affine coordinate on  $\mathbb{C}\mathbb{P}^1$ , such that  $B \cong z_1 = z_2 = 0$  and  $f = z_1/z_2$ . This is equivalent to saying that near  $b$  the graph of  $f$  is given by

$$((z_1, \dots, z_n, t), [z_1 : z_2]) \subset M \times \mathbb{C}\mathbb{P}^1. \quad (24)$$

In these coordinates  $\tilde{M}$  coincides with the complex blow up in the first two coordinates, and therefore it is a submanifold.

The first projection restricts to the blow down map  $\pi: \tilde{M} \rightarrow M$ , which is the identity away from  $B$  and collapses each  $\{b\} \times \mathbb{C}\mathbb{P}^1 \subset \tilde{M}$  to  $b \in B \subset M$ . The restriction to  $\tilde{M}$  of the second projection on  $M \times \mathbb{C}\mathbb{P}^1$  defines an extension of  $f$

$$\tilde{f}: \tilde{M} \rightarrow \mathbb{C}\mathbb{P}^1.$$

Because we are blowing up directions inside leaves we have an induced foliation  $\tilde{\mathcal{F}}$ , and the blow down map is a map of foliated manifolds.

The fibers of  $\tilde{f}$  are transverse to  $\tilde{\mathcal{F}}$ , and by construction the restriction of the projection  $\pi: \tilde{f}_z \rightarrow W_z$  is a diffeomorphism foliated manifolds. We let  $\tilde{F}$  denote the leaf mapping into  $F$ .

Let  $\tilde{\omega}$  denote the pullback of  $\omega$  by the blow down map. We claim that the intersection of the fibers of  $\tilde{f}$  with  $\tilde{\mathcal{F}}$  are symplectic manifolds with respect to  $\tilde{\omega}_{\tilde{\mathcal{F}}}$ , and therefore there is an associated leafwise Ehresmann connection which extends  $\mathcal{H}$ . At a point  $p = (b, [z_1 : z_2])$ , say  $z_2 \neq 0$ , the tangent space  $T_{[z_1:z_2]}\mathbb{C}\mathbb{P}^1 \subset T_{(b,[z_1:z_2])}\tilde{F}$  is in the kernel of  $\tilde{\omega}_{\tilde{\mathcal{F}}}$  because the blow down map collapses the  $\mathbb{C}\mathbb{P}^1$  factor into the point  $b$ . The subspace  $T_{(b,[z_1:z_2])}\tilde{f} \cap T_{(b,[z_1:z_2])}\tilde{F}$  is complementary

to  $T_{[z_1:z_2]}\mathbb{C}\mathbb{P}^1$  and it is mapped isomorphically into  $T_b f_{z_1/z_2} \cap T_b F$ , and the latter is symplectic with respect to  $\omega_{\mathcal{F}}$  (alternatively, in local coordinates about the base point  $T_b f_{z_1/z_2} \cap T_b F$  is a complex hyperplane of  $T_0\mathbb{C}^n$ , and therefore it is symplectic with respect to  $\omega_{\mathcal{F}}$  because the symplectic form has type  $(1, 1)$  at the origin). Thus, the blow down map identifies  $\tilde{f}_z$  and  $W_z$  as 2-calibrated foliations.

Once we have described the kernel of  $\tilde{w}_{\mathcal{F}}$ , it is easy to see that the horizontal lift of  $\gamma \subset \mathbb{C}\mathbb{P}^1$  starting at  $(b, \gamma(0))$  is exactly  $(b, \gamma)$ .

It is clear that parallel transport defines a Poisson equivalence. It is obviously an equivalence of 2-calibrated foliations because (the induced) co-orientations are preserved, and the 2-calibrations are restriction of the same closed 2-form on  $M$ .  $\square$

Let  $c \in \Delta$  be a critical point and let us apply theorem 5 to construct Morse coordinates for  $f$  centered at  $c$ . By restricting Morse coordinates to the leaf  $F$  containing  $c$ , we obtain Morse coordinates for the restriction of  $f$  to  $F$ . Since the restriction of  $\omega_{\mathcal{F}}$  to  $F$  is mapped to a symplectic form of type  $(1, 1)$  at the origin, leafwise parallel transport near  $c$  corresponds to parallel transport in  $\mathbb{C}^n \setminus \{0\}$  near 0 for the function  $h$  with respect to a symplectic form of type  $(1, 1)$  at the origin.

Let us consider the following system of neighborhoods of the critical point  $0 \in \mathbb{C}^n$  ([36], section 1.2): we fix the standard symplectic form  $\Omega_{\mathbb{R}^{2n}}$  and define  $\Sigma_z$ ,  $z \in \mathbb{C}$ , to be the Lagrangian sphere of points in  $h_z$  whose parallel transport over the radial segment converges to the origin. For some  $r_0 > 0$  we fix the parametrization

$$\varphi_{r_0}: (T_{r_0}(\lambda), \Omega_{\mathbb{R}^{2n}}) \rightarrow (T(\lambda), d\alpha_{\text{can}}).$$

For any  $z \in \mathbb{C}$  small enough we define  $T_z(\lambda) \setminus \Sigma_z$  by radial parallel transport to the origin and then to  $r_0$ . Of course,  $T_z(\lambda)$  denotes the union of  $T_z(\lambda) \setminus \Sigma_z$  and  $\Sigma_z$ .

Then

$$\mathcal{T}(\lambda, r) = \bigcup_{z \in \bar{D}(r)} T_z(\lambda), \quad \lambda, r > 0 \quad (25)$$

is a system of neighborhoods of the origin. We also have the corresponding annular subsets  $\mathcal{A}(\lambda, \lambda', r, r')$ .

**Lemma 7.** *Let  $\Omega_u$ ,  $u \in K$ , be a compact family of symplectic forms defined on a neighborhood  $W$  of  $0 \in \mathbb{C}^n$  which make the fibers  $h_z$  symplectic submanifolds. Let us fix any  $\lambda, r > 0$ ,  $\lambda' \in (0, \lambda)$  and  $r' \in (0, r)$ . Then there exists  $\delta > 0$  such that for any curve  $\gamma \subset \bar{D}(r') \setminus \{0\}$  having the  $C^1$ -norm of  $\gamma - \gamma(0)$  bounded by  $\delta$ , the horizontal lift  $\tilde{\gamma}_u$  starting at any  $p \in \mathcal{T}(\lambda', r')$  is contained in  $\mathcal{T}(\lambda, r)$ , for all  $u \in K$ .*

*Proof.* Let  $\mathcal{C}$  denote the topological space of (piecewise embedded or constant) curves contained in  $\bar{D}(r)$  relative to the  $C^1$ -topology. Let us consider the subset

$$E = \{(\gamma, p, u, v) \in \mathcal{C} \times \mathcal{A}(\lambda', \tilde{\lambda}, r, r') \times K \times [0, 1] \mid \gamma(0) = h(p)\},$$

and let us define the continuous map

$$\begin{aligned} G: E &\longrightarrow W \\ (\gamma, p, u, v) &\longmapsto \tilde{\gamma}_u(v), \end{aligned}$$

by sending a tuple to the evaluation for time  $v$  of the horizontal lift of  $\gamma$  with respect to  $\Omega_u$  starting at  $p$ . The map is not everywhere defined since horizontal lifts may leave  $W$  or converge to the critical point, which is exactly what we want to control. However, inside  $E$  we have the subset  $\mathcal{A}(\lambda', \tilde{\lambda}, r, r') \times K \times [0, 1]$  corresponding to constant curves. The restriction of  $G$  to this subset is the first projection. By continuity an open neighborhood of  $\mathcal{A}(\lambda', \tilde{\lambda}, r, r')$  inside  $E$  is sent into  $\mathcal{T}(\lambda, r)$ . Because on  $E$  we have the topology induced by the product topology, we conclude the existence of  $\delta$  such that curves with  $\|\gamma - \gamma(0)\|_{C^1} < \delta$ ,  $\gamma(0) \in \bar{D}(r')$ , have horizontal lift starting at points in  $A_{\gamma(0)}(\lambda', \tilde{\lambda})$  contained in  $\mathcal{T}(\lambda, r)$ . If in addition

such a small curve does not contain  $0 \in \mathbb{C}$ , the connectivity argument already used a couple of times implies that horizontal lifts starting at points in  $T_{\gamma(0)}(\lambda')$  remain inside  $\mathcal{T}(\lambda, r)$ , and this proves the lemma.  $\square$

**Remark 9.** Let  $\sigma \in \mathbb{C}$  and consider the constant perturbation of the complex quadratic form  $h + \sigma$ . Note that in the definition of  $\mathcal{T}(\lambda, r) \subset \mathbb{C}^n$  for  $h$  given in (25), if we replace radial segments joining a point  $z$  to the origin by segments joining  $z$  to  $\sigma$ , we get exactly the same subset  $\mathcal{T}(\lambda, r)$ . Now assume that the parameter  $u \in K$  in lemma 7 describes not just the variation of symplectic forms, but a perturbation of  $h$  by a constant  $\sigma(u)$ . Then lemma 7 holds replacing in the statement  $h$  by  $h + \sigma$  and the disk of radius  $r'$  by the disk of radius  $r'$  centered at  $\sigma(u)$ .

**5.2. Connected components of  $W_z \cap F$  and leafwise parallel transport.** Let us fix  $z_0 \in \mathbb{CP}^1$  a regular value for  $f$ . Let  $\gamma \subset \mathbb{CP}^1$  be a loop based at  $z_0$  with empty intersection with  $f(\Delta_F)$ . Lemma 6 implies that parallel transport over  $\gamma$  defines a diffeomorphism on  $W_{z_0} \cap F$  (actually a symplectomorphism). Therefore the loop acts on connected components of  $W_{z_0} \cap F$  and the action descends to  $\pi_1(\mathbb{CP}^1 \setminus f(\Delta_F), z_0)$ .

**Proposition 4.** *The action of  $\pi_1(\mathbb{CP}^1 \setminus f(\Delta_F), z_0)$  on connected components of  $W_{z_0} \cap F$  is trivial.*

*Proof.* Let  $\gamma$  be a loop based at  $z_0$  and not intersecting  $f(\Delta_F)$ . Consider  $H_s$  a homotopy connecting  $H_0 = \gamma$  with the constant path  $z_0$ . We can assume without loss of generality that  $H$  misses a point of  $\mathbb{CP}^1$ , and therefore compose with an affine coordinate chart and work in  $\mathbb{C}$ .

We can assume as well that the curves  $\gamma_s$  in the homotopy coincide in the complement of an interval  $[a, b] \subset [0, 1]$ , and the  $C^1$ -norm of  $\gamma_{[a, b]} - \gamma(a)$  (rescaled to have domain  $[0, 1]$ ) is bounded by any given  $\delta > 0$ : by breaking the domain of  $H$  into  $n^2$  squares of side  $1/n$ , we can write  $H$  as composition of  $n^2$  homotopies with the above property. It is possible that the starting curve  $\gamma_0$  of each of the  $n^2$  homotopies does intersect  $f(\Delta_F)$ , but intersections can be removed after a perturbation with does not affect the behavior we demand on the curves  $\gamma_s$ .

We are going to control how the lifts of the curves in the homotopy behave near  $\Delta_F$  using Morse coordinates, and away from  $\Delta_F$  using a compactness argument.

Let  $c \in \Delta$  and let us construct Morse coordinates  $z_1, \dots, z_n, t$  as in definition 8. We say that the restriction of the coordinates to each plaque in their domain are Morse coordinates for the restriction of  $f$  to the plaque. In Morse coordinates for a given plaque the restriction of  $f$  transforms into  $h + \sigma(t)$  and  $\omega_{\mathcal{F}}$  transforms into a symplectic form of making the fibers  $(h + \sigma(t))_z$  symplectic manifolds (this is because we can construct Morse coordinates centered at any point in  $\Delta$ , and in Morse coordinates on the plaque containing  $c$  the perturbation  $\sigma(t)$  can be taken to be trivial and  $\omega_{\mathcal{F}}$  becomes a symplectic form of type  $(1, 1)$  at the origin).

Let us cover  $\Delta$  with a finite number of Morse coordinates and let us consider their associated 1-parameter families of Morse coordinates on their plaques. Let us take  $\lambda, r > 0$  such that  $\mathcal{T}(\lambda, r)$  as defined in (25) is contained in the image of Morse coordinates for each of the plaques. Let us also pick  $\lambda' \in (0, \lambda)$ ,  $r' \in (0, r)$  and denote by  $U$  the points in  $\tilde{M}$  whose image by at least one of the sets of Morse coordinates on its plaque is contained in  $\mathcal{T}(\lambda', r')$ . Note that  $U$  is a neighborhood of  $\Delta$ .

For each of our Morse coordinates its 1-parameter family of Morse coordinates on plaques is in the hypothesis of lemma 7, or rather remark 9 (we assume that the parameter space is a compact interval, and that these compact intervals cover  $\Delta$ ). Let  $\delta_1$  be a  $C^1$ -bound provided by remark 9 and valid for the finite number of 1-parameter families.

Let  $V \subset V'$  be open neighborhoods of  $\Delta$  in  $\tilde{M}$  such that  $V \subset \bar{V} \subset V' \subset U$ . Because  $\tilde{M} \setminus V'$  is compact, there exists  $\delta_2 > 0$  such that for any  $p \in \tilde{M} \setminus V'$  and any curve  $\gamma \subset \mathbb{C}\mathbb{P}^1$  starting at  $\tilde{f}(p)$  and such that the  $C^1$ -norm of  $\gamma - \gamma(0)$  is bounded by  $\delta_2$ , the horizontal lift  $\tilde{\gamma}$  starting at  $p$  is contained in  $\tilde{M} \setminus V$ .

Let  $\delta$  be the minimum of  $\delta_1$  and  $\delta_2$  as let us assume that for each  $\gamma_s$  in our homotopy  $H$  the  $C^1$ -norm of  $\gamma_{s|[a,b]} - \gamma_s(a)$  is smaller than  $\delta$ . Let  $\gamma_0$  and  $\gamma_1$  be the starting and ending curve of the homotopy and let  $\tilde{\gamma}_0$  and  $\tilde{\gamma}_1$  be their respective horizontal lifts starting at  $p \in W_{z_0} \cap F$ . We claim that  $\tilde{\gamma}_0(1)$  and  $\tilde{\gamma}_1(1)$  can be connected by a path in  $W_{z_0} \cap F$ , what would prove the proposition.

Recall that  $\gamma_s$ ,  $s \in [0, 1]$ , is independent of  $s$  in the complement of  $[a, b] \subset [0, 1]$ .

Let us suppose that  $\tilde{\gamma}_0(a) \in \tilde{M} \setminus V'$ . Because of the  $C^1$ -bound on  $\gamma_{s|[a,b]} - \gamma_s(a)$ ,  $s \in [0, 1]$ , the horizontal lifts of  $\gamma_{s|[a,b]}$  starting at  $\tilde{\gamma}_0(a)$  are defined for all  $s \in [a, b]$  and belong to  $\tilde{M} \setminus V$ . In particular  $\tilde{\gamma}_s(b)$  is a curve in the fiber  $\tilde{f}_{\gamma_0(b)}$ . Since the curves  $\gamma_{s|[b,1]}$  are all equal and avoid  $f(\Delta_F)$ , we can construct the horizontal lift starting at all points in the path  $\tilde{\gamma}_s(b)$ . What we just proved is that the homotopy  $H_s$  has a well defined lift starting at  $p$ , and therefore  $\tilde{\gamma}_s(1)$  connects  $\tilde{\gamma}_0(1)$  to  $\tilde{\gamma}_1(1)$ .

If  $\tilde{\gamma}_0(a) \in V$  then it also belongs to  $U$ . If we compose with one of the fixed Morse coordinates on the plaque  $u_0$  containing  $\tilde{\gamma}_0(a)$ , the point  $\tilde{\gamma}_0(a)$  is sent to  $q \in \mathcal{T}(\lambda', r')$ . The curves  $\gamma_{0|[a,b]}$  and  $\gamma_{1|[a,b]}$  meet the hypothesis of lemma 7 (remark 9), and therefore their horizontal lifts starting at  $q$  are contained in  $\mathcal{T}(\lambda, r)$ . In particular the images  $q_0$  and  $q_1$  of  $\tilde{\gamma}_0(b)$  and  $\tilde{\gamma}_1(b)$  respectively belong to  $(h + \sigma(u_0))_{\gamma_0(b)}$ . All regular fibers of  $h + \sigma(u_0)$  in  $\mathcal{T}(\lambda, r)$  are diffeomorphic to  $T(\lambda)$  and therefore they are connected. Let  $\zeta$  be a path in  $(h + \sigma(u_0))_{\gamma_0(b)}$  connecting  $q_0$  to  $q_1$ . Let us also denote by  $\zeta$  its image in the plaque  $u_0$  by the Morse chart, which belongs to  $\tilde{f}_{\gamma_0(b)}$ . Then the ending points of the lifts of  $\gamma_{0|[b,1]}$  starting at  $\zeta(v)$ ,  $v \in [0, 1]$ , connect  $\tilde{\gamma}_0(1)$  to  $\tilde{\gamma}_1(1)$ .  $\square$

Proposition 4 is the key result to “spread” a connected component of  $W_{z_0} \cap F$  onto  $F$ . Before, we need to show that  $W_{z_0} \cap F$  is always non-empty. For that it suffices to prove that  $\tilde{f}(F)$  contains some regular value  $z$  of  $\tilde{f}$ , because in that case we can use parallel transport over a curve joining  $z$  to  $z_0$  and avoiding singular values of  $f(\Delta_F)$ , to find points in  $W_{z_0} \cap F$ : because  $\tilde{M}$  is compact the regular values of  $\tilde{f}$  (which are the regular values of  $f$ ) are an open dense subset. The subset  $\tilde{f}(F) \subset \mathbb{C}\mathbb{P}^1$  has not empty interior and therefore it contains regular values.

**Theorem 6.** *Let  $(M^{2n+1}, \mathcal{F}, \omega)$ ,  $n > 1$ , be a 2-calibrated foliation and let  $(f, B, \Delta)$  be a Lefschetz pencil structure as in definition 8. Then any regular fiber  $W$  of the pencil intersects every leaf of  $\mathcal{F}$  in a unique connected component.*

*Proof.* Let  $z_0$  be a regular value and let  $F$  be a leaf. We let  $C$  be a non-empty connected component of  $W_{z_0} \cap F$  (it always exists since  $W_{z_0} \cap F$  is non-empty). Let us define  $\Gamma_C$  to be the set of horizontal curves starting at  $C$  and whose projection  $\tilde{f} \circ \zeta$  is either an embedded curve or constant. We define

$$F_C := \{p \in F \setminus \Delta_F \mid \exists \zeta \in \Gamma_C, \zeta(1) = p\}.$$

By construction  $F_C$  is non-empty, connected and contains  $C$ . We want to show that it is open.

Let  $p \in F_C$  such that the horizontal curve  $\zeta$  connects  $x \in C$  with  $p$ . Let us suppose that the curve  $\tilde{f} \circ \zeta$  is embedded (it is not constant). Then we can find a 1-parameter family of embedded curves  $\gamma_s$ ,  $s \in (-\epsilon, \epsilon)$ , defined for time  $v \in [0, 1 + \epsilon]$ , and such that the restriction of  $\gamma_0$  to  $[0, 1]$  is  $\tilde{f} \circ \zeta$ . Because  $\zeta$  is contained in  $\tilde{M} \setminus \Delta$ , a compactness argument implies that there exists  $A$  an open neighborhood of  $x$  inside  $C$  and  $\epsilon' > 0$ , such that the horizontal lift of  $\gamma_{s|[0,1+\epsilon']}$  starting at any point

in  $A$  exists for all  $s \in (-\epsilon', \epsilon')$ . It is clear that for  $\epsilon'$  small enough

$$U_p = \{y \in F \mid y = \tilde{\gamma}_s(v), \tilde{\gamma}_s(0) \in A, v \in (1 - \epsilon', 1 + \epsilon'), s \in (-\epsilon', \epsilon')\}$$

is a neighborhood of  $p$  in  $F_C$ .

If  $\zeta$  is constant we make the previous construction for a family of radial curves starting at  $z_0$ , and the open neighborhood is obtained considering horizontal lifts for time  $v \in [0, \epsilon')$  starting at a neighborhood  $A$  of  $p$  inside  $C$  (we would be “spreading” the open subset  $A$ ).

We claim that  $F_C$  does not contain a connected component of  $W_{z_0} \cap F$  different from  $C$ . Suppose the contrary. Then we would have a loop  $\gamma$  with a horizontal lift connecting two different connected components of  $W_{z_0} \cap B$ . Since after a small perturbation we can assume without loss of generality that  $\gamma$  does not intersect  $\Delta_F$ , this would contradict proposition 4.

Because it is clear that any point in  $F \setminus \Delta_F$  can be connected to  $W_{z_0} \cap F$  by a horizontal curve lifting an embedded curve, we conclude that connected components of  $W_{z_0} \cap F$  are in bijection with connected components of  $F$ , and this proves that  $W_{z_0} \cap F$  is connected.  $\square$

*Proof of theorem 1.* Let  $(M, \mathcal{F}, \omega)$  be a 2-calibrated foliation. If it is not integral, compactness of  $M$  implies that we can slightly modify  $\omega$  into  $\omega'$  so that a suitable multiple  $k\omega'$  defines an integral homology class. Theorem 5 implies the existence of a Lefschetz pencil  $(f, B, \Delta)$ .

Therefore by theorem 6 any regular fiber  $(W, \mathcal{F}_W, k\omega'_W)$  intersects every leaf in a connected component. If the dimension of  $W$  is bigger than 3, we apply the same construction to  $(W, \mathcal{F}_W, k\omega'_W)$ . By induction we end up with a 3-dimensional manifold with a taut foliation  $(W^3, \mathcal{F}_W) \hookrightarrow (M, \mathcal{F}, \omega)$ , whose intersection with every leaf of  $\mathcal{F}$  is connected.  $\square$

*Proof of theorem 2.* Let  $l: W \hookrightarrow M$  be a submanifold as in theorem 1. Because for all  $F \in \mathcal{F}$  the intersection  $W \cap F$  is connected, the map  $l$  descends to a bijection of leaf spaces

$$\tilde{l}: W/\mathcal{F}_W \rightarrow M/\mathcal{F}.$$

Open sets of  $W/\mathcal{F}_W$  (respectively  $M/\mathcal{F}$ ) are in one to one correspondence with saturated open sets of  $W$  (respectively  $M$ ).

Let  $V$  be a saturated open set of  $(M, \mathcal{F})$ . By definition  $W \cap V$  is an open set of  $W$  which is clearly saturated (even without the assumption of  $\tilde{l}$  being a bijection) and this shows that  $\tilde{l}$  is continuous.

Now let  $V$  be an open saturated set of  $(W, \mathcal{F}_W)$ . We want to show that its saturation in  $(M, \mathcal{F})$ , denoted by  $\overline{V}^{\mathcal{F}}$ , is open to conclude that  $\tilde{l}$  is open.

If  $V$  is a saturated set and  $x \in V$ , then  $x$  is an interior point if and only if for some  $T_x$  a local manifold through  $x$  transverse to the foliation,  $x$  is an interior point of  $T_x \cap V$ . Hence, every  $x \in V$  is an interior point of  $\overline{V}^{\mathcal{F}}$ . By using the holonomy, if a point in a leaf is interior the whole leaf is made of interior points. Since every leaf of  $\overline{V}^{\mathcal{F}}$  intersects  $V$ ,  $\overline{V}^{\mathcal{F}}$  is open, and this proves the theorem.  $\square$

**5.3. Regular fibers and Lagrangian surgery.** Let  $W$  be a regular fiber of a Lefschetz pencil structure for  $(M, \mathcal{F}, \omega)$ . Theorems 6 and 5 describe the topology of  $W/\mathcal{F}_W$  and part of the homology and homotopy of  $W$ , in terms of the corresponding data for  $(M, \mathcal{F})$ . We want to understand how different regular fibers of the pencil are related as 2-calibrated foliations.



Let  $z$  and  $z'$  be regular values of the pencil belonging to the same connected component of  $\mathbb{CP}^1 \setminus f(\Delta)$ , and let  $\gamma$  be a curve in that connected component connecting  $z$  to  $z'$ . Then lemma 6 implies that  $\rho_\gamma: W_z \rightarrow W_{z'}$  is an equivalence of 2-calibrated foliations.

We notice that any two arbitrary regular values  $z$  and  $z'$  can always be joined by a curve  $\gamma$  transverse to  $f(\Delta)$ .

**Theorem 7.** *Let  $z, z' \in \mathbb{CP}^1$  be two regular values. Let  $\gamma$  be an embedded curve joining  $z$  and  $z'$  and transverse to  $f(\Delta)$ . Then  $f^{-1}(\gamma)$  is a cobordism between  $W_z$  and  $W_{z'}$  which amounts to adding one  $n$ -handle for each point  $x \in \Delta$  such that  $f(x) \subset \gamma$ . More precisely, if  $n > 2$  and there is only one critical point  $c \in f^{-1}(\gamma)$ , then there exists  $L \subset W_z \setminus B$  a framed Lagrangian sphere such that  $W_{z'}$  is the result of performing generalized Dehn surgery on  $W_z$  along  $L$ . The framed sphere are the points in  $W_z$  which under parallel transport over  $\gamma$  converge to  $c$ .*

*Proof.* Let  $w \in \gamma$  and  $c \in \Delta$  with  $f(c) = w$ . Let us take Morse coordinates around  $c$  and an affine chart on  $\mathbb{CP}^1$ . Let us assume for simplicity that the curve  $\gamma$  in the affine chart coincides with a segment of the real axis. For  $r > 0$  small enough, we want to construct a Poisson equivalence

$$\phi: W_r \rightarrow W_{-r}$$

To that end consider the cobordism  $Z = \tilde{f}^{-1}(x_0(-r, r))$ , which is a manifold with boundary because  $\tilde{f}$  is transverse to  $\gamma$  ( $\text{Im}\sigma'(0) \neq 0$ ). The attaching of the handle in this elementary cobordism occurs in a neighborhood of  $c$ , or equivalently in a neighborhood of 0 of the Morse chart, which is where we work from now on.

We are going to arrange the current setting so that it becomes analogous to the one in theorem 4.

The pullback of  $f$  to the  $t$ -leaf of  $\mathbb{C}^n \times \mathbb{R}$  is  $h + \sigma(t)$ . After reparametrization of the coordinate  $t$ , we may assume without loss of generality that  $\sigma(t) = (a(t), t)$ .

The tangent space of  $Z$  at  $0 \in \mathbb{C}^n \times \mathbb{R}$  is the hyperplane  $t = 0$ . Therefore the projection  $Z \rightarrow \mathbb{C}^n$  is a local diffeomorphism with image an open neighborhood  $V$  of  $0 \in \mathbb{C}^n$ .

We define  $\phi$  away from a neighborhood  $V' \subset V$  of  $0 \in \mathbb{C}^n$  as follows:

$$\phi := \rho_{x_0(-r, r)}: W_r \rightarrow W_{-r}.$$

We claim that it is possible to extend  $\phi$  to an equivalence of 2-calibrated foliations repeating the proof of theorem 4 with two minor modifications.

Let us define  $\sigma_r(t) := (r, 0) + \sigma(t)$ ,  $r \neq 0$ ,  $t \in [-\epsilon, \epsilon]$ . Hence the image of  $W_r$  (respectively  $W_{-r}$ ) on  $V'$  is exactly  $h^{-1}(\sigma_r(t))$  (respectively  $h^{-1}(\sigma_{-r}(t))$ ). Recall that Morse coordinates on the  $t$ -plaque send  $\omega_{\mathcal{F}}$  to a symplectic form  $\Omega_t$  which makes the fibers of  $h + \sigma(t)$  symplectic. Then it follows that the morphism  $\rho_{x_0(-r, r)}: W_r \rightarrow W_{-r}$  at a point  $p \in V' \cap W_r$  in the  $t$ -leaf corresponds to parallel transport  $\rho_{t, x_t(r+a(t), -r+a(t))}$  (with respect to  $\Omega_t$ ).

The first modification we need to introduce is composing all curves used in the proof of theorem 4 and defined in a neighborhood of  $0 \in \mathbb{C}$ , with the diffeomorphism

$$(x, y) \mapsto (x + a(y), y).$$

The second difference is that from the very beginning our parallel transport here is with respect to a family of symplectic forms  $\Omega_t$ , and with  $\Omega_0$  of type  $(1, 1)$  at the origin. This situation is not quite new since in the proof of theorem 4 we already needed to interpolate symplectic forms (although at a later stage).

Hence we conclude that for  $r$  small enough the fiber  $W_{-r}$  is equivalent to Lagrangian surgery (and hence by theorem 4 generalized Dehn surgery) along a framed

Lagrangian sphere  $L$ ; the Lagrangian sphere are the points in  $W_r$  which parallel transport over  $x_0(r, 0)$  sends to the critical point  $c$ .  $\square$

**Remark 10.** *Theorem 7 is rather natural in view of the results for contact manifolds in [31].*

**5.4. Further directions.** In this paper we have shown that 2-calibrated foliations are a wide enough class of codimension one foliations, and not surprisingly, techniques from symplectic geometry are well suited to their study. We would like to finish by discussing a couple of questions that we were not able to answer.

Theorem 2 shows that our embedded 3-dimensional taut foliations capture the leaf space of  $\mathcal{F}$ . What it would be interesting to know is whether they capture the full transverse geometry, i.e. the holonomy groupoid.

A remarkable property of 3-dimensional taut foliations is that transverse loops are never nullhomotopic. The proof of this fact uses that the universal cover of the 3-manifold is  $\mathbb{R}^3$ , a property which does not extend to manifolds supporting a 2-calibrated foliation. We know no examples 2-calibrated foliations on simply connected manifolds: in [20] it was shown that normal connected sum could be used to construct 5-dimensional simply connected regular Poisson manifolds with codimension one leaves. Those methods, however, cannot be used to construct simply connected 2-calibrated for conditions in theorem 3 are not fulfilled. It has been recently shown that Lawson's foliation on  $S^5$  is the symplectic foliation of a Poisson structure [29]. However, this Poisson structure does not admit a 2-calibration because Lawson's foliation is not taut (the compact leaf would make any transverse loop non-trivial in homology).

We conjecture that any transverse loop in a 2-calibrated foliation is not nullhomotopic.

## 6. APPENDIX: LEGENDRIAN SURGERY, OPEN BOOK DECOMPOSITIONS AND GENERALIZED DEHN SURGERY

Let  $(M, \xi)$  be an exact contact manifold and let  $\alpha$  be a contact 1-form defining  $\xi$  ( $\xi = \text{Ker}\alpha$ ). Recall that an open book decomposition for  $M$  is given by a pair  $(K, \theta)$  such that

- $K$  is a codimension 2 submanifold with trivial normal bundle, referred to as the binding;
- $\theta: M \setminus K \rightarrow S^1$  is a fibration that in a trivialization  $D^2 \times K$  of a neighborhood of  $K$  is the angular coordinate.

Let  $F$  denote the closure of any fiber of  $\theta$ . The first return map associated to a suitable lift of  $\frac{\partial}{\partial \theta}$  to  $M \setminus K$ , defines a diffeomorphism of  $F$  supported away from a neighborhood of the boundary  $\partial F = K$ . Up to diffeomorphism  $M$  can be recovered out of  $F$  and the first return map.

The following discussion is mostly taken from [11]:

**Definition 9.** *The contact structure  $\xi$  is supported by an open book decomposition  $(K, \theta)$  if for a choice of contact form  $\alpha$  defining  $\xi$  we have:*

- $\alpha$  restricts to  $K$  to a contact form.
- $d\alpha$  restricts to each fiber of  $\theta$  to an exact symplectic structure.
- The orientation of  $K$  as the boundary of each symplectic leaf matches the natural orientation induced by the contact form.

*The form  $\alpha$  is said to be adapted to the open book decomposition  $(K, \theta)$ .*

In what follows we are going to discuss contact structures and cosymplectic foliations on a given manifold. Since we have been using the notion of Reeb vector field

for cosymplectic foliations, we refer to contact Reeb vector fields when discussing contact structures.

Given a contact form  $\alpha$  adapted to  $(K, \theta)$ , it is possible to scale it away from  $K$  to a contact 1-form  $\alpha'$  such that the flow along its contact Reeb vector field defines a compactly supported first return map  $\varphi \in \text{Symp}(\text{int}F, d\alpha')$  [11].

The isotopy class of  $(M, \xi)$  is totally determined by any open book decomposition supporting it [10, 11]. More precisely, the relevant structure in the open book decomposition is the completion of the structure of exact symplectic manifold convex at infinity of the exact symplectic fiber  $(\text{int}F, d\alpha)$  (or  $(\text{int}F, d\alpha')$ ), together with the first return symplectomorphism supported inside  $\text{int}F$ .

The previous characterization becomes very important in light of the following theorem:

**Theorem 8.** [10, 11] *For every exact contact manifold  $(M, \xi)$  and any contact form defining  $\alpha$ , there exist an open book decomposition  $(K, \theta)$  supporting  $\xi$  such that  $\alpha$  is adapted to it.*

Let  $\alpha$  be a contact form on  $M$  adapted to the open book decomposition  $(K, \theta)$  and let  $L$  be a parametrized Legendrian sphere which is contained in a fiber of  $\theta$ , and hence it becomes Lagrangian for the symplectic structure  $d\alpha$  on the fiber.

Observe that away from the binding  $K$ , the open book decomposition defines a 2-calibrated foliation  $(M \setminus K, \mathcal{F}_\theta, d\alpha)$ , with  $\mathcal{F}_\theta = \text{Ker}d\theta$ , which is a symplectic mapping torus associated to the symplectomorphism  $\varphi$  supported in  $\text{int}F$ . Generalized Dehn surgery along  $L$  produces a new symplectic mapping torus with return map  $\varphi \circ \tau$ , where  $\tau$  is a generalized Dehn twist along  $L$ . Because the symplectic leaf is the same and the return map is still compactly supported, the symplectic mapping torus is in fact the open book decomposition of a unique contact manifold (up to isotopy). In [11] it has been announced that this contact manifold is  $(M^L, \alpha^L)$  the result of performing Legendrian surgery along  $L$  [39].

The ideas developed relating Lagrangian surgery and generalized Dehn surgery allow us to give a very natural proof of this result. The key step is the following theorem.

**Theorem 9.** *Let  $L \subset (M, \alpha)$  be a parametrized Legendrian sphere in a contact manifold and let  $(M^L, \alpha^L)$  be the contact manifold obtained by Legendrian surgery along  $L$ . Suppose that  $\alpha$  is adapted to the open book  $(K, \theta)$  and that  $L$  is contained in a fiber of  $\theta$ . Then given  $V$  any small enough neighborhood of  $L$  with empty intersection with the binding  $K$ , there exists an isotopy  $\Psi_s: M \rightarrow M$ ,  $s \in [0, 1]$ , starting at the identity with the following properties:*

- $\Psi_s$  is supported inside  $V$  and tangent to the identity at  $L$ .
- $(M \setminus K, \mathcal{F}_{\theta_s}, d\alpha)$ , with  $\mathcal{F}_{\theta_s} := \Psi_{s*}\mathcal{F}_\theta$ , is a 2-calibrated foliation and thus an open book decomposition  $(K, \Psi_{s*}\theta)$  of  $M$  to which the contact form  $\alpha$  is adapted.
- Let  $(M^L \setminus K, \mathcal{F}_{\theta_1^L}, d\alpha^L)$  be the result of performing generalized Dehn surgery on  $(M \setminus K, \mathcal{F}_{\theta_1}, d\alpha)$  along the parametrized Lagrangian sphere  $L$ . Then  $(M^L \setminus K, \mathcal{F}_{\theta_1^L}, d\alpha^L)$  is an open book decomposition  $(K, \theta_1^L)$  for  $M^L$  and the contact form  $\alpha^L \in \Omega^1(M^L)$  is adapted to  $(K, \theta_1^L)$ .

*Proof.* We are going to recall Weinstein's definition of Legendrian surgery using a symplectic cobordism and a Liouville vector field transverse to the boundary. Actually, we will modify the original choices to make them compatible with our setup for Lagrangian surgery, or by theorem 4 with the setup for generalized Dehn surgery.

Recall that a boundary component of a symplectic manifold  $(Z, \Omega)$  (of dimension bigger than 2) endowed with a Liouville vector field  $Y$  is said to be convex (respectively concave) if  $Y$  is outward (respectively inward) pointing.

We consider  $(M \times [-1, 1], d(e^v \alpha))$ , which is a subset of the symplectization of  $(M, \alpha)$ . The tuple  $(M \times [-1, 1], d(e^v \alpha), \frac{\partial}{\partial v}, M \times \{0\}, L \times \{0\})$  is an isotropic setup in the language of Weinstein ([39], section Neighborhoods of isotropic submanifolds). Note that  $\{1\} \times M$  (respectively  $\{-1\} \times M$ ) is a convex (respectively) concave boundary component (beware that the notion of Liouville vector field we use is opposite to Weinstein's, for we require the flow of the vector field to expand the symplectic form exponentially).

The second isotropic setup is the one of the  $(n+1)$ -handle to be attached, which is the one described in [39], section Standard Handle, up to the following change. Unlike Weinstein does, we are going to glue the convex end of  $(M \times [-1, 1], d(e^v \alpha), \frac{\partial}{\partial v}, M \times \{0\}, L \times \{0\})$  to the concave end of the symplectic  $(n+1)$ -handle; the reason is that in our definition of Lagrangian surgery, we glued the symplectic  $(n+1)$ -handle along the hypersurface  $H_{2,r}$  where the symplectic vector field points inward. For this reason we also define a different Liouville vector field in the  $(n+1)$ -handle. We use the notation introduced in 4.1.

The symplectic form is the standard one  $\Omega_{\mathbb{R}^{2n+2}}$ . We consider the function

$$q = \sum_{i=1}^{n+1} x_i^2 - 2y_i^2,$$

whose negative gradient with respect to the Euclidean metric

$$E = -2x^1 \frac{\partial}{\partial x^1} + 4y^1 \frac{\partial}{\partial y^1} - \dots - 2x^{n+1} \frac{\partial}{\partial x^{n+1}} + 4y^{n+1} \frac{\partial}{\partial y^{n+1}}$$

is a Liouville vector field.

For each  $r > 0$  we consider the fiber  $q_r$ , which contains the Lagrangian sphere  $\Sigma_r$  described in lemma 2 using  $Y_2$  the Hamiltonian vector field of  $-\text{Re}h$  with respect to  $\Omega_{\mathbb{R}^{2n+2}}$ . Notice that  $dq(Y_2) < 0$  and therefore  $Y_2$  is transverse to the level hypersurfaces  $q_r$ . Since  $Y_2$  and  $E$  coincide at  $\Sigma_r$ , it follows that the sphere  $\Sigma_r$  is also Legendrian with respect to the contact form  $\alpha_E := i_E \Omega_{\mathbb{R}^{2n+2}}$  on  $q_r$ . Moreover, at points of  $\Sigma_r \subset q_r$  the contact distribution and the cosymplectic distribution coincide.

Let  $V_r(\epsilon)$  be a tubular neighborhood or radius  $\epsilon > 0$  of  $\Sigma_r$  inside  $q_r$  with respect to the Euclidean metric. We claim that for any  $\epsilon' > 0$ ,  $\epsilon > \epsilon'$ , we have  $f_r \in C^\infty(V_r(\epsilon) \setminus \Sigma_r, \mathbb{R}^+)$  a cut-off function with compact support and with the following two properties:

- $\Phi_1^{f_r Y_2}(V_r(\epsilon') \setminus \Sigma_r) \subset q_{-2r}$  (note that  $q_{-2r}$  contains the Lagrangian sphere  $\Sigma_{-r}$ ).
- $\Phi_1^{f_r Y_2}(V_r(\epsilon))$  is transverse to  $E$ .

Assuming the claim, we define the hypersurface

$$H_r^L := \Phi_1^{f_r Y_2}(V_r(\epsilon) \setminus \Sigma_r) \cup \Sigma_{-r}.$$

By assumption the Liouville vector field  $E$  is transverse to  $H_r^L$ , and thus the hypersurface inherits an exact contact structure  $\alpha_E$  by restricting  $i_E \Omega_{\mathbb{R}^{2n+2}}$ .

The second isotropic setup is the following: the symplectic  $(n+1)$ -handle is the compact region bounded by  $H_r^L$  and  $V_r(\epsilon)$  endowed with the standard symplectic form; the Liouville vector field is  $E$ ; the hypersurface is  $V_r(\epsilon)$ , which is concave; the parametrized Legendrian sphere is  $\Sigma_r$ .

The symplectic morphism  $\psi$  that gives rise to the symplectic elementary cobordism ([39], proposition 4.2, whose replacement for Lagrangian surgery is lemma 1),

sends  $(V_r(\epsilon), \Sigma_r, \alpha_E)$  to  $(\nu(L), L, \alpha)$ , and therefore we can consider  $(V_r(\epsilon), \Sigma_r, \alpha_E)$  as a subset of  $(M, \alpha)$ . Then

$$M^L := H_r^L \cup (M \setminus V_r(\epsilon))$$

carries and obvious contact form  $\alpha^L$  which extends  $(M \setminus V_r(\epsilon), \alpha)$ .

The data for Legendrian surgery has been chosen to be compatible with Lagrangian surgery: both  $H_r^L$  and  $V_r(\epsilon)$  are transverse to  $Y_2$  and therefore they inherit 2-calibrated foliations  $(H_r^L, \mathcal{F}_r^L, \omega_r^L)$  and  $(V_r(\epsilon), \mathcal{F}_r, d\alpha)$ . Theorem 4 easily implies that  $(H_r^L, \mathcal{F}_r^L, \omega_r^L)$  is the result of generalized Dehn surgery along  $\Sigma_r \subset (V_r(\epsilon), \mathcal{F}_r, d\alpha)$ .

On  $V_r(\epsilon)$  we have two structures of 2-calibrated foliation,  $(\mathcal{F}_r, d\alpha)$  and  $(\mathcal{F}, d\alpha)$ . The reason is that  $\psi$  preserves contact forms and hence contact Reeb vector fields, but it does not preserve the 1-forms defining the cosymplectic foliations (or their associated Reeb vector fields). However, at  $\Sigma_r$  the Liouville and Hamiltonian vector field coincide, and this implies that at points in  $L$  the contact distribution is tangent to  $\mathcal{F}_r$ . In particular the contact Reeb vector field for  $\alpha$  is transverse to  $\mathcal{F}_r$  near  $L$ . It is also transverse to  $\mathcal{F}$  because  $\alpha$  is adapted to the open book. Therefore we can use the trajectories of the contact Reeb vector field, to construct an isotopy  $\Psi_s$  tangent to the identity at  $L$  and supported inside  $V$  a small neighborhood of  $\Sigma_r$  contained in  $V_r(\epsilon)$ .

The claim about the existence of the function  $f_r$  is easily proved when  $n = 1$  by inspecting the trajectories of  $E$  and  $Y_2$ . The general case can be reduced to the previous one: each point  $(x_1, y_1, \dots, x_{n+1}, y_{n+1})$  in  $\mathbb{C}^{n+1}$  and away from the union of stable and unstable manifolds (these are the same for both Morse functions  $\text{Re}h$  and  $q$ ), determines  $[x_1 : \dots : x_{n+1}], [y_1 : \dots : y_{n+1}]$  a point in  $\mathbb{RP}^n \times \mathbb{RP}^n$ , which gives rise to two lines in  $\mathbb{R}^{n+1}$  and  $i\mathbb{R}^{n+1}$  respectively. These lines span a plane in  $\mathbb{C}^{n+1} = \mathbb{R} \oplus i\mathbb{R}^{n+1}$ . Each plane in the family is preserved by the flow of  $E$  and  $Y_2$ ; moreover, the flows restrict to the planes to the flows of the 1-dimensional case. From this observation the claim follows easily.  $\square$

Theorem 9 provides an isotopy  $\Psi_s$  supported away from  $K$ , so that  $\alpha$  is adapted to the 1-parameter family of open book decompositions  $(K, \Psi_s\theta)$ . Therefore we can identify the symplectic fiber  $F$  and symplectic monodromy  $\varphi \in \text{Symp}(\text{int}F, d\alpha)$  of  $(K, \theta)$  with those of  $(K, \Psi_1\theta)$  (again following the contact Reeb flow). Hence point 3 in theorem 9 asserts that  $(M^L, \alpha^L)$  is adapted to an open book decomposition with the same symplectic leaf  $(F, d\alpha)$  and monodromy  $\varphi \circ \tau \in \text{Symp}(\text{int}F, d\alpha)$ , which is exactly what we wanted to prove.

**Remark 11.** *If we attach the convex end of the symplectic handle to the concave end of the symplectization, we get the contact manifold  $(M^{L^-}, \alpha^{L^-})$ . It is easy to see that  $\alpha^{L^-}$  is adapted to an open book decomposition whose monodromy is  $\varphi \circ \tau^{-1}$ .*

*Observe that proposition 6.1 in [6] implies that in dimensions 5 and 13 the manifolds  $M^L$  and  $M^{L^-}$  are diffeomorphic. In [24], section 3, it is shown that there are instances (coming from Brieskorn manifolds) in which  $(M^L, \alpha^L)$  and  $(M^{L^-}, \alpha^{L^-})$  are not contactomorphic, and hence the authors can deduce that  $\tau^2$  is not isotopic to the identity in  $\text{Symp}^{\text{comp}}(T^*S^6, d\alpha_{\text{can}})$ , a result already proved by Seidel for  $n = 2$  [34]; similar results are also drawn for powers of the Dehn twists known to be isotopic to the identity in  $\text{Diff}^{\text{comp}}(T(\lambda))$ , for all  $n$  even.*

**Remark 12.** *For any contact form  $\alpha$  on  $M$  representing the given contact structure  $\xi$  and  $L$  a Legendrian submanifold, Giroux and Mohsen announce [11] the existence of relative open book decompositions, meaning that  $\alpha$  is adapted to the open book decomposition and  $L$  is contained in a fiber.*

The interested reader familiar with approximately holomorphic geometry [7] and its version for contact manifolds [23, 31], can write a proof along the following lines: the open book decomposition is the result of pulling back the canonical open book decomposition of  $\mathbb{C}$  by an approximately holomorphic function. To make sure the binding does not contain  $L$ , we use reference sections supported near  $L$  which achieve the value 1 when restricted to  $L$ ; they come from an explicit formula once we identify a tubular neighborhood of  $L$  with a tubular neighborhood of the zero section of the first jet bundle with its canonical contact structure  $(\mathcal{J}^1 L, \alpha_{\text{can}})$ . It is necessary to further add perturbations whose restriction to  $L$  attain real values: they are such that its restriction to  $T^*L \times \{0\} \subset \mathcal{J}^1 L$  are small real multiples of reference sections equivariant with respect to the involution on  $(\mathcal{J}^1, \alpha_{\text{can}})$  which reverses the sign of the fiber and conjugation on  $\mathbb{C}$  (this construction is analogous to the content of the remark after lemma 3 in [3]).

Therefore we conclude that Lagrangian surgery includes Legendrian surgery, for we can bypass the latter by choosing appropriate compatible open book decompositions and then performing Lagrangian surgery. According to theorem 4 we can even claim that generalized Dehn surgery contains Legendrian surgery, and forget about the cobordisms.

Actually, the reason why generalized Dehn surgeries for different open book decompositions supporting the contact structure give the same contact manifold, is because there is a contact surgery behind. Now consider  $(L, \chi)$  where  $L$  is a Legendrian submanifold of  $(M, \alpha)$  and  $\chi \in \text{Symp}^{\text{comp}}(T^*L, d\alpha_{\text{can}})$ . Let us take any open book decomposition relative to  $L$  and such that  $\alpha$  is adapted to it, and consider the new manifold  $M^L$  associated to the open book decomposition with symplectic monodromy  $\varphi \circ \chi$ . It is clear that the diffeomorphism type of the manifold does not depend on the open book decomposition, but it is not clear whether in general the contact structure depends on the choice of open book decomposition. In either case, it would be an interesting situation because it would give either a new contact surgery -possibly a Legendrian surgery based on a block different from a symplectic handle- or different contact structures.

## 7. FUNDING

Partially supported by the Fundação para a Ciência e a Tecnologia (FCT/Portugal), NWO [Symmetries and Deformations in Geometry] (The Netherlands), Pisa University [Galileo Galilei] and Spanish Ministry of Science and Technology [MTM2004-07090-C03].

## REFERENCES

- [1] Alcalde Cuesta, F. “Intégration symplectique des variétés de Poisson régulières sans cycle évanouissant.” *Thèse, Université Claude Bernard - Lyon 1* (1993).
- [2] Auroux, D. “Asymptotically holomorphic families of symplectic submanifolds”. *Geom. Funct. Anal.* 7, no. 6 (1997): 971–995.
- [3] Auroux, D.; Gayet, D.; Mohsen, J.-P. “Symplectic hypersurfaces in the complement of an isotropic submanifold”. (English summary) *Math. Ann.* 321, no. 4 (2001): 739–754.
- [4] Bertelson, M. “Foliations associated to regular Poisson structures.” *Commun. Contemp. Math.* 3, no. 3 (2001): 441–456.
- [5] Bertelson, M. “A  $h$ -principle for open relations invariant under foliated isotopies.” *J. Symplectic Geom.* 1, no. 2 (2002): 369–425.
- [6] Durfee, A., Kauffman, L. “Periodicity of branched cyclic covers.” *Math. Ann.* 218, no. 2 (1975): 157–174.
- [7] Donaldson, S. K. “Symplectic submanifolds and almost-complex geometry.” *J. Differential Geom.* 44 (1996): 666–705.
- [8] El Kacimi-Alaoui, A. “Sur la cohomologie feuilletée”. *Compositio Math.* 49 no. 2 (1983): 195–215.

- [9] Fernandes, R.; Frejlich P.: “A h-principle for symplectic foliations”. To appear in *Int. Math. Res. Not.* (2011). Doi 10.1093/imrn/rnr077.
- [10] Giroux, E. “Géométrie de contact: de la dimension trois vers les dimensions supérieures.” *Proceedings of the International Congress of Mathematicians* Vol. II (Beijing, 2002): 405–414,
- [11] Giroux, E., Mohsen, J.-P. “Structures de contacte et fibrations symplectiques au-dessus du cercle.” *Lecture notes.*
- [12] Gotay, M. “On coisotropic imbeddings of presymplectic manifolds.” *Proc. Amer. Math. Soc.* 84, no. 1 (1982): 111–114.
- [13] Gotay, M., Lashof, R., Sniatycki, J., Weinstein, A. “Closed forms on symplectic fibre bundles.” *Comment. Math. Helv.* 58, no. 4 (1983): 617–621.
- [14] Gompf, R. “A new construction of symplectic manifolds.” *Ann. of Math.* (2) 142, no. 3 (1995): 527–595.
- [15] Gompf, R., Stipsicz, A., “4-manifolds and Kirby calculus”. Graduate Studies in Mathematics, 20. American Mathematical Society, Providence, RI, 1999.
- [16] Greene, R. E., Shiohama, K. “Diffeomorphisms and volume-preserving embeddings of noncompact manifolds.” *Trans. Amer. Math. Soc.* 255 (1979): 403–414.
- [17] Guillemin, V., Miranda, E., Pires, A. R., “Codimension one symplectic foliations and regular Poisson structures”. *Bull. Braz. Math. Soc. (N.S.)* 42 (2011), no. 4, 607–623.
- [18] Harvey, R., Lawson, H. “Calibrated foliations (foliations and mass-minimizing currents).” *Amer. J. Math.* 104, no. 3 (1982): 607–633.
- [19] Hofer, H., Zehnder, E. “Symplectic invariants and Hamiltonian dynamics.” *Birkhauser Advanced Texts: Basel Textbooks.* Birkhauser Verlag, Basel (1994).
- [20] Ibort, A., Martínez Torres, D. “A new construction of Poisson manifolds.” *J. Symplectic Geom.* 2, no. 1 (2003): 83–107.
- [21] Ibort, A., Martínez Torres, D. “Approximately holomorphic geometry and estimated transversality on 2-calibrated manifolds.” *C. R. Math. Acad. Sci. Paris* 338, no. 9 (2004): 709–712.
- [22] Ibort, A., Martínez Torres, D. “Lefschetz pencil structures for 2-calibrated manifolds.” *C. R. Math. Acad. Sci. Paris* 339, no. 3 (2004): 215–218.
- [23] Ibort, A., Martínez Torres, D., Presas, F. “On the construction of contact submanifolds with prescribed topology.” *J. Differential Geom.* 56, no. 2 (2000): 235–283.
- [24] van Koert, O., Niederkrüger, K. “Open book decompositions for contact structures on Brieskorn manifolds.” *Proc. Amer. Math. Soc.* 133, no. 12 (2005): 3679–3686.
- [25] Lickorish, W. “A foliation for 3-manifolds.” *Ann. of Math.* (2) 82 (1965): 414–420.
- [26] McDuff, D., Salamon, D., “Introduction to symplectic topology”. Second edition. Oxford Mathematical Monographs. The Clarendon Press, Oxford University Press, New York, 1998.
- [27] de Melo, W., Palis, J. “Geometric Theory of Dynamical Systems, an introduction.” *Springer Verlag* (1982).
- [28] Melvin, P., “2-sphere bundles over compact surfaces”. *Proc. Amer. Math. Soc.* 92 (1984), no. 4, 567–572.
- [29] Mitsumatsu, Y., “Leafwise Symplectic Structures on Lawson’s Foliation”. Preprint arXiv:1101.2319
- [30] Ohsawa, T., Sibony, N., “Kähler identity on Levi flat manifolds and application to the embedding”. *Nagoya Math. J.* 158 (2000): 87–93.
- [31] Presas, F. “Lefschetz type pencils on contact manifolds.” *Asian J. Math.* 6, no. 2 (2002): 277–301.
- [32] Rummeler, H. “Quelques notions simples en gomtrie riemannienne et leurs applications aux feuilletages compacts. *Comment. Math. Helv.* 54, no. 2 (1979): 224–239.
- [33] Sacksteder, R. “Foliations and pseudogroups.” *Amer. J. Math.* 87 (1965): 79–102.
- [34] Seidel, P. “Lagrangian two-spheres can be symplectically knotted.” *J. Differential Geom.* 52, no. 1 (1999): 145–171.
- [35] Seidel, P. “Graded Lagrangian submanifolds.” *Bull. Soc. Math. France* 128, no. 1 (2000): 103–149.
- [36] Seidel, P. “A long exact sequence for symplectic Floer cohomology.” *Topology* 42, no. 5 (2003): 1003–1063.
- [37] Sullivan, D. “Cycles for the dynamical study of foliated manifolds and complex manifolds.” *Invent. Math.* 36 (1976): 225–255.
- [38] Thurston, W. “Existence of codimension-one foliations.” *Ann. of Math.* (2) 104, no. 2 (1976): 249–268.
- [39] Weinstein, A. “Contact surgery and symplectic handlebodies.” *Hokkaido Math. J.* 20, no. 2 (1991): 241–251.

*E-mail address:* `martinez@math.ist.utl.pt`

CENTRO DE ANÁLISE MATEMÁTICA, GEOMETRIA E SISTEMAS DINÂMICOS, DEPARTAMENTO DE MATEMÁTICA, INSTITUTO SUPERIOR TÉCNICO, AV. ROVISCO PAIS, 1049-001 LISBOA, PORTUGAL



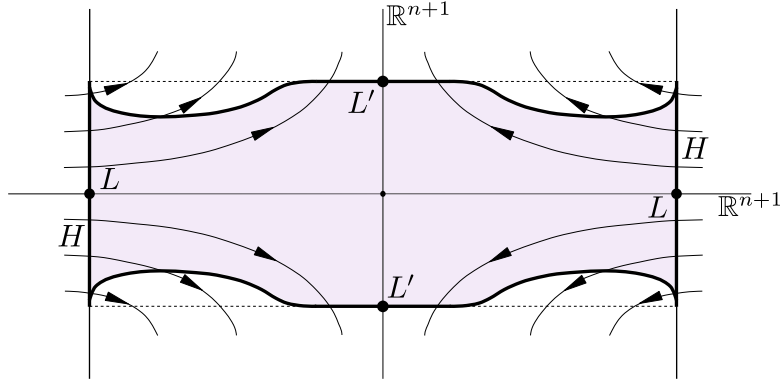

FIGURE 1. The modified handle is the shaded region, which is everywhere transverse to the gradient flow lines. The dotted segments are part of the boundary of the standard handle with corners.

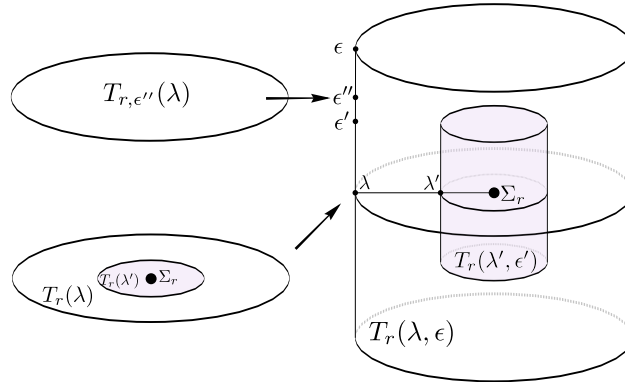

FIGURE 2. In the r.h.s. appear the neighborhoods  $T_r(\lambda, \epsilon)$  and  $T_r(\lambda', \epsilon')$  (shaded) of the Lagrangian sphere  $\Sigma_r$ . Horizontal slices correspond to intersections with leaves of the foliation. In the l.h.s. appear the slice  $t = 0$ , which intersects both  $T_r(\lambda, \epsilon)$  and  $T_r(\lambda', \epsilon')$ , and the slice  $t = \epsilon''$  which does not intersect  $T_r(\lambda', \epsilon')$ .

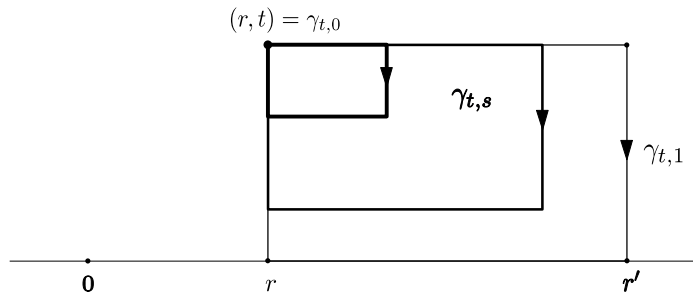
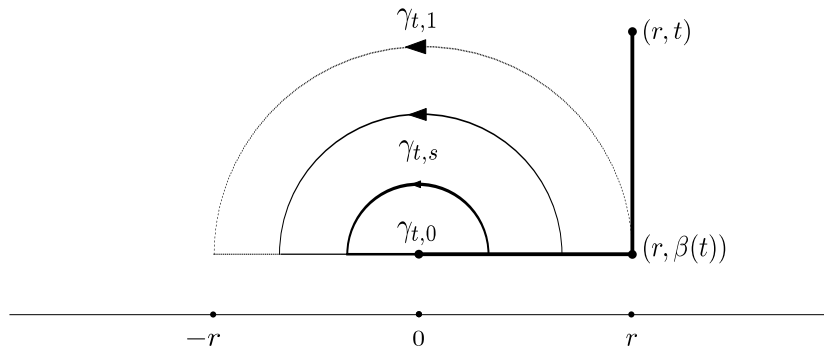

FIGURE 3. A family of curves shrinking  $\gamma_{t,1}$  the boundary of the rectangle to the vertex  $(r, t)$

FIGURE 4. The curves  $\gamma_{t,s}$  defined in (20).